

Appendix A – KPFF Memos (A.1 through A.4)

A.1 - Due Diligence Phase 1 Report

Building 46 (Hangar 2) and Building 47 (Hangar 3)

Due Diligence Phase 1 Report

August 9, 2013

Building history

Hangars 2 and 3 are the world's largest freestanding wood-frame structures constructed by the U.S. Navy in 1942 to aid the WWII efforts and the "lighter-than-air" (LTA) program. These hangars are integrated with a total of 17 other identical hangars that were constructed across the U.S. to house dirigibles such as the USS Macon and the USS Akron. To conserve metal resources for the war efforts, the 17 hangars were primarily constructed of wood and concrete, as shown in Figure 1. Hangars 2 and 3 are officially addressed as Buildings 46 and 47, respectively, on the NASA Ames Research Center historic properties.



Figure 1. 1942 Hangar 2 Construction.

The primary structural aspects of Hangars 2 and 3 involve 51 timber arches that are spaced 20 feet on center and rise above the slab on grade approximately 170 feet to the arch outer chord. The timber arches are orientated in the transverse direction and connected at the base to a two-story transverse concrete bent. The concrete bents are located on concrete pile caps and timber piles with an allowable load capacity of 12 tons each. The outer and inner footings of the bent consist of 9 and 12 piles, respectively, where 3 piles in each group were battered to resist an outward dead and wind thrust loads. The arches and the concrete bents are supported in the longitudinal direction by timber cross braces. However, at various locations throughout the hangars, the cross braces have been retrofitted with either steel braces or steel cables. Two inch diagonal tongue and groove timber sheathing encloses the hangars on the outer chords of the arches, as well as the exterior roof assembly of an asphaltic material and corrugated aluminum. The latter was a replacement in 1956 for the original tarpaper rolled roofing.

The doors at the north and south ends of each hangar consist of six aluminum and wood frame sliding panels. These doors are guided by rails on slab as well as through a transverse box beam spanning between two concrete towers. The box beam is a double-height wood truss sheathed with wood diagonal tongue and groove patterns. The box beam is approximately 20 ft square and cantilevers 20 ft beyond

each tower, as shown in Figure 2. The tower and box beam assembly are attached to the timber hangar through anchor bolts embedded into the concrete towers. The supporting structure for the hangar doors is a free standing structure and separated from the timber hangar by a gap separating the two structures. Similar to the concrete bents, the towers are supported on concrete pile caps and timber piles with an allowable load of 30 tons each. A total of 816 piles were used for all towers of a single hangar. The main footprint of both hangars is approximately 296'6"x1000'. A two-story annex building measuring 62'x1000' was added to the east side of Hangar 3 in 1945 for additional office and shop space.



Figure 2. 2013 Hangar 2 (nearest hangar) and Hangar 3.

Numerous problems arose during the design and construction phases of the hangars. The primary challenge at the time was the lack of knowledge in detailing, fabricating, treating, and handling the mass amount of timber required. Research and testing were not allocated by the project because it was considered part of the Accelerated Public Works Program of the Navy in aid of the war efforts.

Documents reviewed

1. Ambrose Group, Inc. (2012).
2. Page & Turnbull, Inc. (2006), "Re-use Guidelines," NASA Ames Research Center, [Hangars 2 & 3].
3. Supplements to Page & Turnbull, Inc. (2006)
 - a. Degenkolb (2006) [Chapter 5]
 - b. Flynn et al. (2002), "An Initial Evaluation of Douglas Fir Wood Components in Hangars 2 and 3 at the NASA/Ames Research Center," UC Forest Products Laboratory.
 - c. Dolei and Team (2000), "Encompassing Synopsis of the Condition and Feasible Utility of Blimp Hangars 2 & 3."
 - d. BAMSI, Inc. (1994), "Hangar 3 Exerpts of Moffett Field Hangar Life Safety Evaluation," Moffett Field Development Project, Plant Engineering Office.
 - e. Rutherford & Chekene (R&C) (1992) [Analysis for only Hangar 3]
 - f. R&C (1984-'85) [Analysis for only Hangar 2]
4. Neal, Donald W. (1986), "Restoration of Navy LTA (Lighter than air) Hangars", Conf. Proceed. in Evaluation and Upgrading of Wood Structures: Case Studies, ASCE, pp. 1-12.
5. Amirikian, A. (1943), "Navy Develops All-Timber Blimp Hangar," ASCE Civil Engineering, Vol. 13, No. 10 and 11.

Summary of previous reports

Numerous assessments of the wood conditions have been documented over the years. The most recent documentation was in 2012 by Ambrose Group, Inc. for only Hangar 2. A thorough non-invasive and non-destructive visual inspection was completed for the interior structural members of the hangar, as well as for the interior of the box beams and overhead catwalks. The inspection noted visual signs of warping and splitting of the main trusses, with the largest crack measured 3.5" wide by 10' in length. In addition, there were multiple cases of missing and compromised fasteners, splitting of tieback and brace members, deflection of the exterior horizontal joints, signs of water staining, and timber shedding throughout the hangar. Similarly, the condition of the box beams showed signs of water intrusion and timber shedding. Splitting was also observed on the cross bracing within the south box beam. The catwalks and ladders used to ascend to the upper catwalk appeared to be in fair and slightly less fair condition, respectively. However, both contained age cracks and showed signs of vertical and lateral deflections when walking on, according to the report.

Page & Turnbull's 2006 Re-Use Guidelines for Hangars 2 and 3 included a detailed description of the historical context, the structural and non-structural systems and their conditions, as well as the re-use methodology. Page & Turnbull advised that the hangars do not comply with the ASCE 31-03 Life Safety performance level. If an earthquake were to occur, major structural damage could result. Therefore, a Full Building Tier 2 analysis was recommended. In addition, the report stated that the members were overstressed due to wind loading. The report recommended that further analysis should follow the guidelines of the California Historical Building Code (CHBC) for seismic and ASCE 7 for wind. The CHBC states that the seismic forces to be used for evaluation and possible strengthening need not exceed 0.75 times the seismic forces prescribed by the 1995 edition of the California Building Code (CBC). The seismic forces would be computed based on R_w forces tabulated in the CBC for similar lateral force resisting systems. Based on past history with this type of construction, there is potential of complete collapse during a major earthquake, excessive wind, or small fire within the vicinity.

Page & Turnbull and the NASA Ames project managers suggested three new uses for Hangar 2 and 3. The possibly scenarios were:

- Scheme 1: Missile Defense Command Center (Low Occupancy, High-Level Security)
- Scheme 2: Federal Emergency and Management Agency Storage Facility (Low Occupancy, Low-Level Security)
- Scheme 3: Public Use Sports Arena and Club (High Occupancy, Low-Level Security)

For each scheme, Page & Turnbull listed recommended improvements based on the level of occupancy and security. The improvements addressed issues of structural inspection/repair, fire protection, emergency systems, MEP, accessibility, egress, doors, windows, new raised topping slab, and new architectural finishes. However, it is recommended that NASA Ames compile a complete analysis for the re-use impacts regarding code issues, structural and system upgrades, accessibility requirements, hazardous materials abatement, envelope repairs, and the alterations of the historic fabric. In addition, because Hangar 2 and 3 are considered historic buildings, all work to the hangar should comply with The Secretary of the Interior's Standards for the Treatment of Historic Properties with Guidelines for Preserving, Rehabilitating, Restoring, and Reconstructing Historic Buildings.

As a section within the re-use guidelines, Page & Turnbull (2006) reference Degenkolb (2006) in Chapter 5 regarding the historical context of the structural systems and a chronological documentation of the structural retrofits and analyses conducted. The report makes note of the hangars having an original design loading, which is similar to the data presented in Amirikian (1943), of the following:

Earthquake = 10% x W

Wind = 10 psf windward + 19 psf suction at the base + 24 psf suction at top of arch

Hoist = 5 kips at panel points near catwalks

Live = Not considered

The considered load combinations were D, D+W, D+EQ, and D+Hoist+0.5W

Also, the allowable material specifications for the original timber design was:

Arch trusses = 1400 psi bending, 1100 psi compression

Other members = 1200 psi bending, 1000 psi compression

In addition, Degenkolb (2006) performed a limited ASCE 31-03 analysis, assuming Site Class D soils, to confirm the general conclusions from previous analyses. The results of this study were identical to those provided by R&C (1984-'85), who conducted a full dynamic analysis of Hangar 2. The corresponding R&C analyses assumed stick models depicting the response of the structure as well as considered foundation stiffness by springs. For a single arch frame in the transverse direction, the truss was modeled as a beam to reduce the number of members analyzed. A similar concept was conducted for the bottom chord bracing in the longitudinal direction. The concrete tower and door structures were analyzed by hand calculations.

The results from R&C analyses are summarized by the following:

- The concrete bents were severely overstressed in bending and inadequately reinforced for ductile behavior.
- All connections of the longitudinal bracing trusses were overstressed.
- The horizontal members of the longitudinal trusses were determined inadequate.
- The concrete door towers were overstressed in bending at the top and base.

The retrofit schemes presented by R&C (1984-'85) involve the addition of concrete wall infill to every third existing concrete bent, construction of a new concrete diaphragm at the top of the concrete bents, strengthening of all overstressed longitudinal bracing connections and horizontal members with steel tubes, and construction of two new concrete struts to brace each tower.

However, to preserve the historical structural context of the hangars, Degenkolb provided an alternative retrofit scheme of strengthening the concrete bents and towers along with the installation of a new pile foundation. In addition, Degenkolb addressed the inadequate spacing of the seismic joint separating the timber hangar from the tower and box beam assembly, as well as documenting that no calculations have been performed on the expandable hangar doors. R&C estimated the overall structural and non-structural repair for only Hangar 2 was [REDACTED] and [REDACTED], respectively. However, it was assumed that similar retrofit costs and analysis results were applicable for Hangar 3.



In 1992, R&C performed an analysis of only Hangar 3 as defined by FEMA 178 (NEHRP Handbook for Seismic Evaluation of Existing Buildings, 1992). The results concluded that the structure did not satisfy the criteria for minimum NEHRP Life Safety performance. Concern was raised on a soft story in the concrete frames because of inadequate reinforcing, inadequate connections of the diagonal bracing, and a complete lack of connection from the diaphragm to the concrete foundation. In addition, it was observed that two adjacent arches contained 1” cracks on the bottom and top chords around the location of the apex. The recommendations emphasized the damaged arches were life safety hazards and must be repaired. The retrofit schemes for Hangar 3 followed the same guideline as the 1984 retrofits, but with the addition of strengthening to the two-story building annex.

Degenkolb (2006) performed an analysis considering the effects of wind and gravity. The results showed overstressed wood braces throughout the hangars under wind loading. However, Degenkolb highlighted that their analysis was limited and recommended that prior to hangar re-use, a comprehensive wind analysis must be performed using ASCE 7 wind design criteria. In addition, Degenkolb advised that Hangars 2 and 3 are susceptible to severe seismic shaking but are not located within the near-field effects of any fault systems. A site specific geotechnical analysis was not performed. However, both hangars are vulnerable to soil liquefaction as classified by the Association of Bay Area Governments.

Degenkolb also noted that Hangar 2 contains structural select Douglas-fir wood with Minalith fire retardant treatment (FRT). The latter was observed by teeth pressed incisions into the wood, as well as fibers littered on the surface of the wood and throughout the floors. On the contrary, Hangar 3 does not have the same FRT and the wood is an alternate species of Douglas-fir. This was validated in the UC Forest Products Laboratory report by Flynn et al. (2002). Further analyses of the wood in Hangar 3 indicate a darker appearance when compared to Hangar 2, as well as a lack of teeth pressed incisions. However, crystals were noted on the surface of the wood indicating a salt based FRT formulation used in Hangar 3. It was also noted that if either of the wood is burned, the low toxicity Chromium III existing within the wood converts to Chromium IV and thus is more toxic (Flynn et al., 2002).

Table 1. Retrofit cost projection for hangar code compliance (Dolci and Team, 2000)

Function	Hangar 2	Hangar 3	Total
Maintenance/Repair M.E.&P.			
Structural/Seismic Upgrades			
Fire Protection			
Roof Repair			
Hazard Remediation			
Code Compliance (M&E), OSHA (occupational Safety), ADA			
Total			
Demolition			

Dolci and Team (2000) provided retrofit cost projections for the hangars (see Table 1). In addition, they noted that Hangar 3 was in better condition than Hangar 2. KPFF Consulting Engineers do not support this statement based on the recent site visit observations. Dolci and Team also studied an alternative use for 747 aircraft and stated that the existing 10” concrete slab floor of the hangars cannot support a fully loaded 747 aircraft. It was recommended that the floor be removed and replaced with a 14.5” reinforced concrete slab if this use was being considered.

Neal (1986) discusses the 1981 assessment and retrofits for Hangars 2 and 3. Between the two hangars, there were a total of 1,513 minor repairs, 18 damaged frame members, and 36 locations of buckling at the arch frames. No structural analysis was conducted by the Navy, but rather the retrofit efforts were confined to restoring the distressed members to their original condition. The retrofit solution for buckled members involved additional glulam bypass members. Neal indicates there was no secondary buckling following the repair of a buckled chord segment.

Summary of recent site visit

KPFF conducted a site visit for Hangars 2 and 3 on July 31 and August 1, 2013, accompanied by Ronald Anthony, wood scientist of Anthony & Associates. It was observed that Hangar 3 appears to be in worse condition than Hangar 2. A large number of timber arches were strengthened by additional timber bypass members, clamps, stitch bolts, and steel cables, as shown in Figure 3. These restoration efforts were primarily completed by Power-Anderson, Inc. in 1981-'87, as mentioned in Neal (1986) and Page & Turnbull (2006), and thereafter in 1995 by Philo & Sons, Inc.

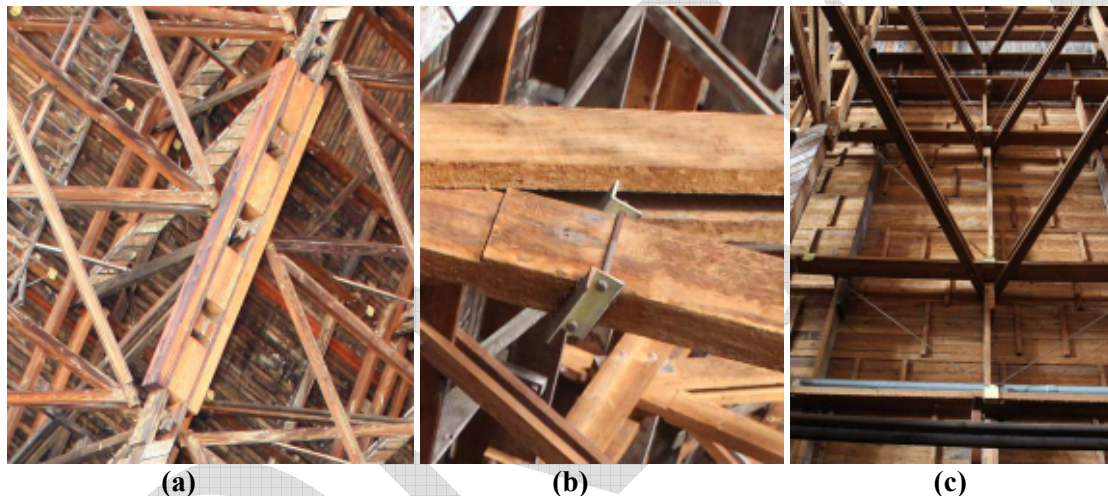

Figure 3. Retrofit techniques observed throughout Hangars 2 and 3 (a) Strengthening of arch chords by addition of glulam bypass members (b) Clamps and stitch bolts to close small cracks (c) Replacement of wood sag braces with steel cables and bolts.

However, to the best of our knowledge, there is no documentation within past 10 years of a full assessment to the condition of Hangar 3. Our recent site visit observed additional cracks in the wood and distortions of the main arch chords near the apex of multiple arches. This is shown in Figure 4 for the specified arch lines and nodal positions. For reference, the arch lines range from 1 to 51, where line 1 depicts the southernmost arch and line 51 represents the northernmost arch. The nodal positions describe the vertical locations of the horizontal joints. Node 0 and node 36 are respectively defined at the base of the arch on the east and west sides (top of the concrete bent). The arch apex is depicted as node 18.

As seen in Figure 4, a significant amount of cracking and out-of-plane distortion is observed on the bottom and top chords of the timber arches. The most prominent cracks are located in the bottom chord of arch 21 at node 16 and in the top chord of arch 22 at node 16. Both cracks widths are approximately 8” and contribute to the appearance of torsionally warped members. The latter could be a direct result of the out-of-plane relative distortion, as seen between nodes 16 and 17 within the bottom chord of arch 22.

This general observation is emphasized in Figure 5 with the relative lateral displacement between the apex of the arch and a theoretical reference line connecting adjacent arch nodes. Similar results are also displayed in Figure 6 for the top chord of arch 18.

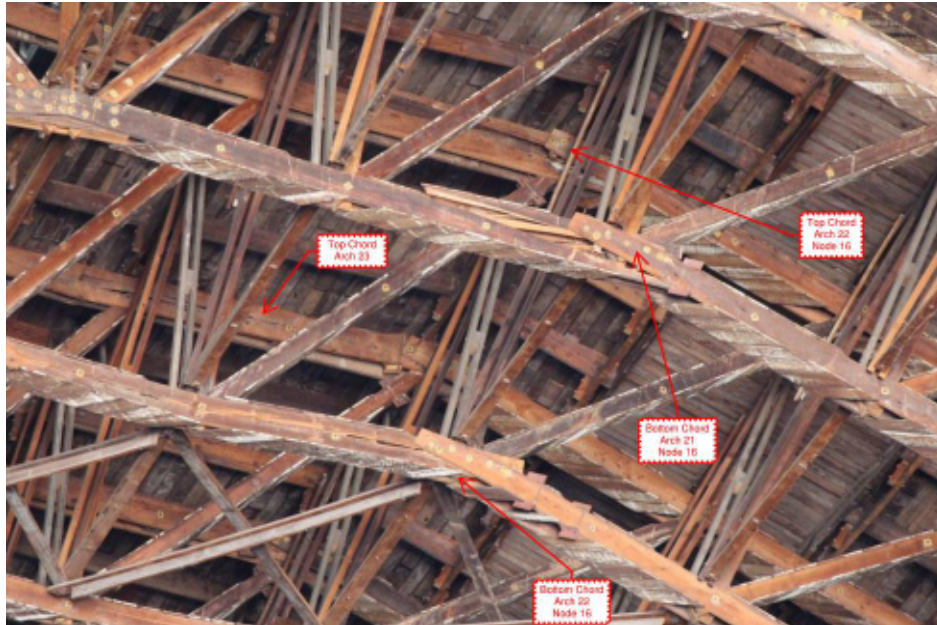

Figure 4. Observed cracks and distortion of the timber arch bottom and top chords in Hangar 3.



Figure 5. Relative lateral displacement between arch apex and reference line for Hangar 3 single arch.

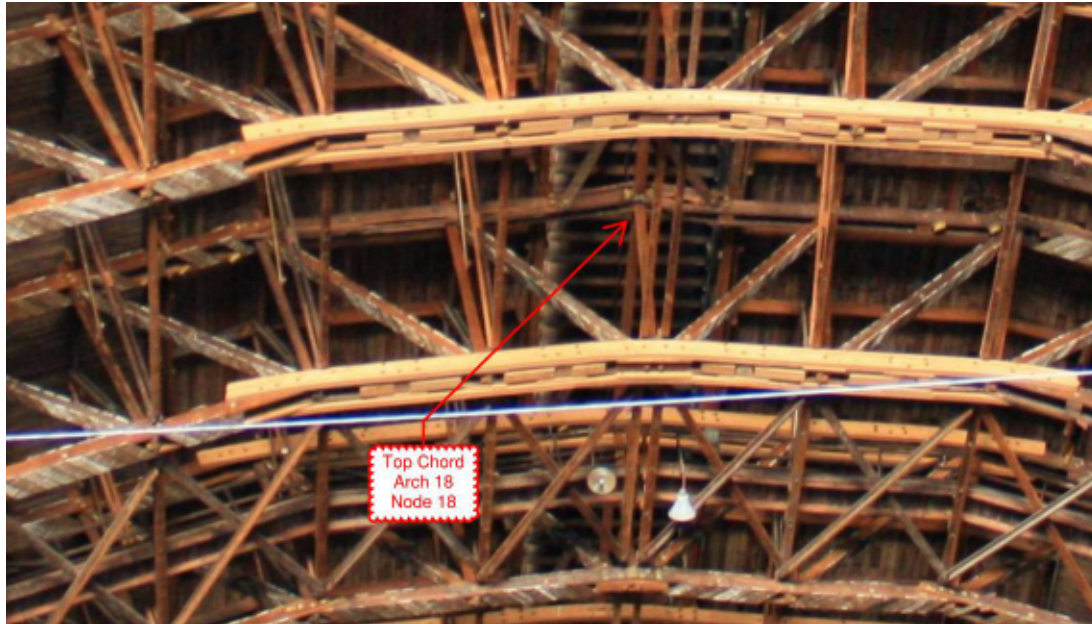

Figure 6. Observed cracks and lateral displacement of arch top chord in Hangar 3.

In addition, it was observed that the apex of numerous arches contain a consistent trend of node 18 displacing relative to the adjacent nodes supporting the monitor (exterior protrusion of the hangar at the apex outer chord). This is displayed in Figure 5 for arch 11, Figure 6 for arch 18, and Figure 7 for arches 21 and 22. The latter contains blue sketch-up arrows displaying the relative lateral displacement of the nodes, where node 18 appears to display south. It is unknown whether or not if all of the observed cracks and distortions propagated from the 1995 retrofits or if their origin emanated within the past couple of months.



Figure 7. General trend of relative lateral displacement at the arch apex top chord in Hangar 3.

Hangar 2 did not have the extent of distress as seen in Hangar 3. There was only one location where the main arches were strengthened by glulam bypass members. This location was on arch line 14 and between nodes 28 and 30. The only visual signs of distress were observed through end splits of cross braces, as shown in Figure 8. This distress was common at locations where the fasteners were too close to the end grains.



Figure 8. Example location of end split in cross brace member within Hangar 2.

It was also observed while walking through the office spaces that various concrete bents in Hangar 2 are braced in the weak axis with steel HSS horizontal and cross braces. This was documented by Page &

Turnbull (2006). However, wide flange steel shapes were also observed for additional reinforcement of the concrete bents in the strong axis, as shown in Figure 9.

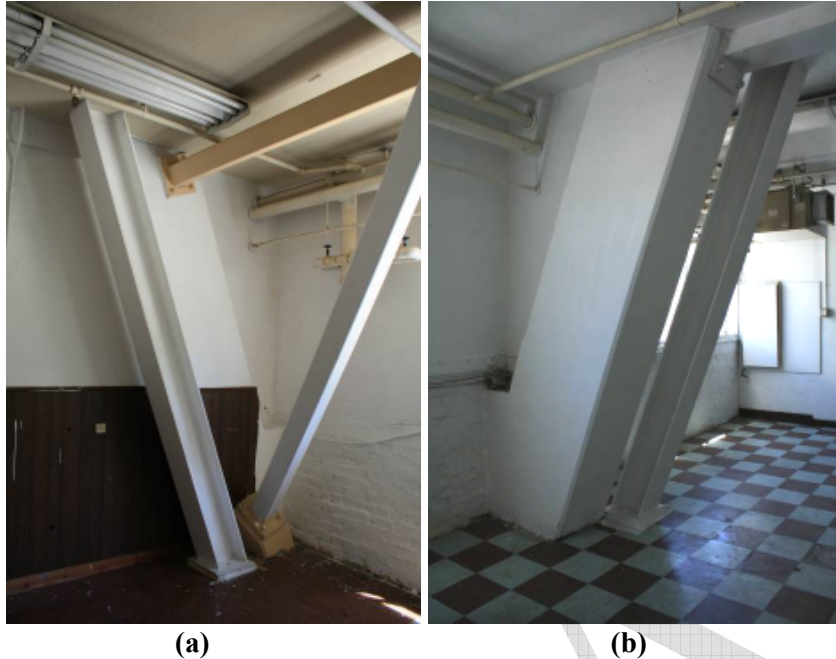

Figure 9. Hangar 2 office space retrofits (a) Longitudinal HSS and Lateral I-Shape bracing (b) Lateral I-Shape and HSS bracing.

While on the recent site visit, it was also observed that the doors on the southwest corner of Hangar 3 were open while all other doors between both hangars were closed. Therefore, future observations must verify if the doors are operable. In addition, the existing corrugated aluminum sheathing was detached at various locations along the roof of Hangars 2 and 3, as shown by example in Figure 10.

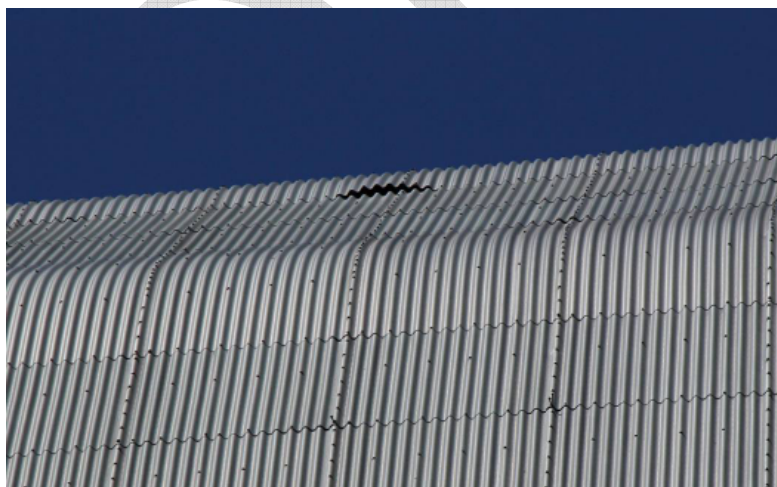

Figure 10. Example location of detached corrugated aluminum sheathing on roof exterior of Hangar 2.



Anthony & Associates provided the following preliminary recommendations through email:

1. “For analysis purposes, the wood species appears to be Douglas-fir in both hangars.
2. For analysis purposes, the grade of the members appears to be Select Structural, Structural Joists & Planks.
3. There appears to be little distress to the timbers in Hangar 2. Some end splits are present when the fasteners are close to the end grain. Seasoning checks are common, but not problematic.
4. Access was quite limited, but there were no signs of visible deterioration due to wood decay fungi. It is likely that there are isolated areas of decay where roof leaks have occurred.
5. As we observed together, there are failures, particularly in the bottom chords of the trusses near the peak of the roof in Hangar 3, that should be further investigated.
6. The effect of the fire-retardant treatment (Minalith in Hangar 2, unknown in Hangar 3) is uncertain. I need to look into this further, but that is likely beyond the scope of this work.”

Summary of recommendations

Based on our review of the existing documents and our site visits, KPFF makes the following recommendations:

1. KPFF concurs with the general retrofit recommendations provided by Rutherford & Chekene, Degenkolb, and Page & Turnbull. Associated pricing can be used as a ROM estimate scaled to today’s dollars. However because of the limitations and assumptions previously presented, KPFF recommends a complete seismic and wind analysis of both hangars using current codes.
2. KPFF recommends immediate correction for the alignment and bracing of the previously mentioned arches for in and out-of-plane movement. Methods of adding glulam bypass members as well as clamps and stitch bolts to the connections provide good potential for restoring the arches back to their original strength. However, it is recommended to monitor adjacent connections and members during restoration as load redistribution could be a potential hazard.
3. KPFF recommends full documentation of all member split end locations. The retrofit techniques will involve clamps, stitch bolts, and some form of epoxy injection.
4. KPFF recommends a survey of the condition of the existing roofing, followed by proposed methods of repair or replacement.
5. KPFF recommends that the project team researches whether the hangar doors are currently operable, and for the team to assess the usable life and anticipated maintenance required for the continued operation of the hangar doors.
6. KPFF recommends a thorough investigation with full accessibility to all interior/exterior structural members and connections for condition assessment and retrofit documentation.
7. KPFF requests a complete set of structural drawings for Hangars 2 and 3, and including all documentation for the Hangar 3 building annex.
8. KPFF recommends a site specific geotechnical assessment for the risk of bay mud consolidation and/or liquefaction effects.

**A.22 - Hangar 3
Emergency Truss Repairs**



Hangar 3 Emergency Truss Repairs Narrative

May 26, 2016

This narrative provides a summary of the current situation and background relevant to the ongoing emergency truss repairs at Moffett Federal Airfield, Hangar 3. We understand that this summary will assist in explaining the context of the Hangar 3 damage and emergency repair work to the wider group of stakeholders involved in this project, including the State Historic Preservation Officer as part of the NHPA Section 106 Consultation.

1 Conditions observed necessitating the need for emergency repair

1.1 Dates of initial and follow up observations

The distressed condition of Hangar 3 was a pre-existing condition that was first observed by the team during the pre-lease RFP Due Diligence phase. Site visits for visual observation were conducted during July and August 2013. Access for visual observations was limited to the hangar deck and some shed areas. KPFF issued a Due Diligence Condition Assessment report on August 23, 2013 documenting the existing member distress observed at the top and bottom chords of the Hangar 3 roof trusses. It is unknown how long the damage existed prior to this time.

The design team progressed with further Due Diligence Investigation activities after the February 10, 2014 selection of Planetary Ventures as the preferred lessee for MFA. Design Development findings were compiled and submitted to the State Historic Preservation Office as support information when a Section 106 consultation package was submitted in May 2015.

In April 2014, DPR Construction began 3D laser scanning operations for Hangars 2 and 3. Site access issues during ongoing lease negotiations delayed the final scan results unto a later date.

Around August 2014, detailed wood condition assessment operations began by Anthony & Associates in coordination with the design team. A combination of visual observation, in-place visual grading, material sampling and testing, and photography was conducted using aerial boom lifts during several weeks of field operations. Preliminary data from the wood condition assessment was delivered to the design team on December 1, 2014. On December 19, 2014, KPFF issued the first draft scope narrative for a Hangar 3 structural monitoring program. This program was recommended based on the severity of prior damage observed and the uncertain timeframe to perform repairs prior to Planetary Ventures' occupancy of MFA.

On February 9, 2015, KPFF was notified of a small piece of wood which fell from the trusses to the ground within Hangar 3. We understand that OSHA was notified in response to this hazard. NASA requested information on the damaged zones of trusses, and KPFF provided a summary of due diligence data collected for Trusses 17–21 on February 13, 2015.

On April 1, 2015, Planetary Ventures took over MFA from NASA. At the PV-NASA meeting on April 8, 2015 to “re kick-off the project”, the Hangar 3 damage was discussed and NASA suggested that conditions reviewed to date did not warrant an expedited review process for emergency repairs.

On June 24, 2015, KPFF performed a routine site visit to observe field conditions of the shed framing in Hangar 2. During that site visit, KPFF also observed Hangar 3 trusses from the deck slab and upon observation, suspected damage progression in the Hangar 3 arched trusses. On June 30, 2015, KPFF performed a follow-up site visit to Hangar 3 with aerial boom lift access and observed severe damage progression and increased excessive truss deflections. Turner Construction provided photographs of the ridge line indicating substantial increased deflection at the roof monitor. KPFF issued findings in engineer's field report EFR-03 along with recommendations for a zone of immediate emergency shoring due to damage progression. Selected photos from EFR-03 are provided below in Figure 1, Figure 2, and Figure 3. A reference truss elevation with panel points labeled is provided in Figure 4.

On July 2, 2015, KPFF issued the Hangar 3 Emergency Truss Repairs set for permit approval. DPR Construction performed another 3D laser scan survey of the trusses at the beginning of August. The permit was received for the emergency repairs, Permit No. 15PV2.300.000, in late August. Construction also began in late August. Coordination between KPFF, Power Engineering Construction, Turner, and the design team for the implementation of shoring and emergency repairs is ongoing as of today.

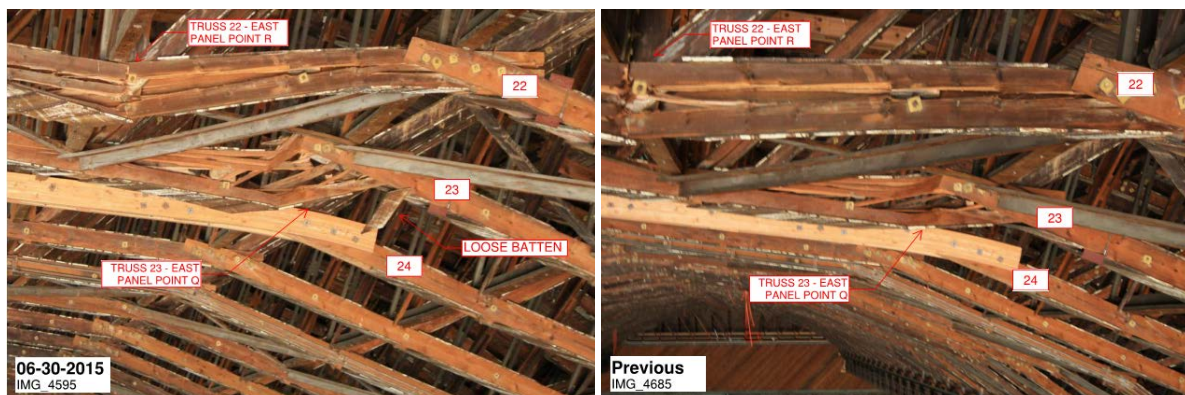

Figure 1. Truss damage progression at Trusses 22 and 23 East near Panel Points R and O.

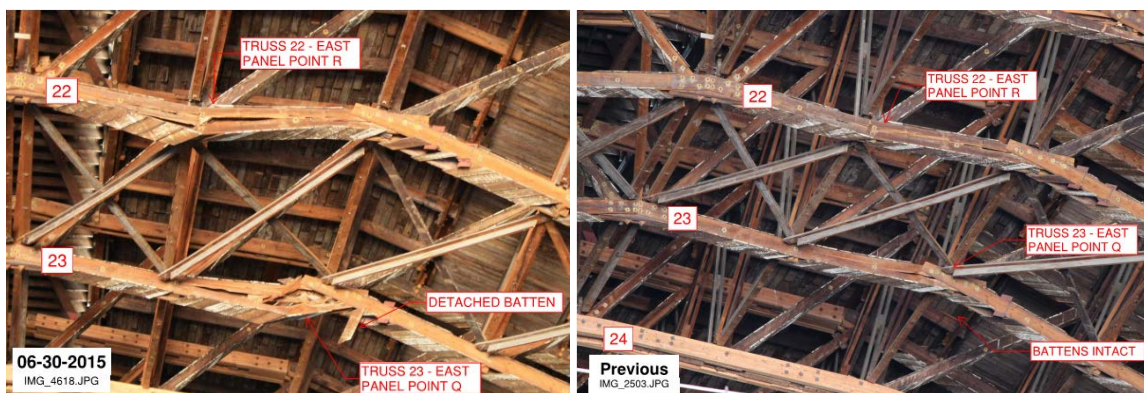

Figure 2. Truss damage progress at Trusses 22 and 23 East near Panel Points R and Q.



Figure 3. Damage observable at ridge line from building exterior.

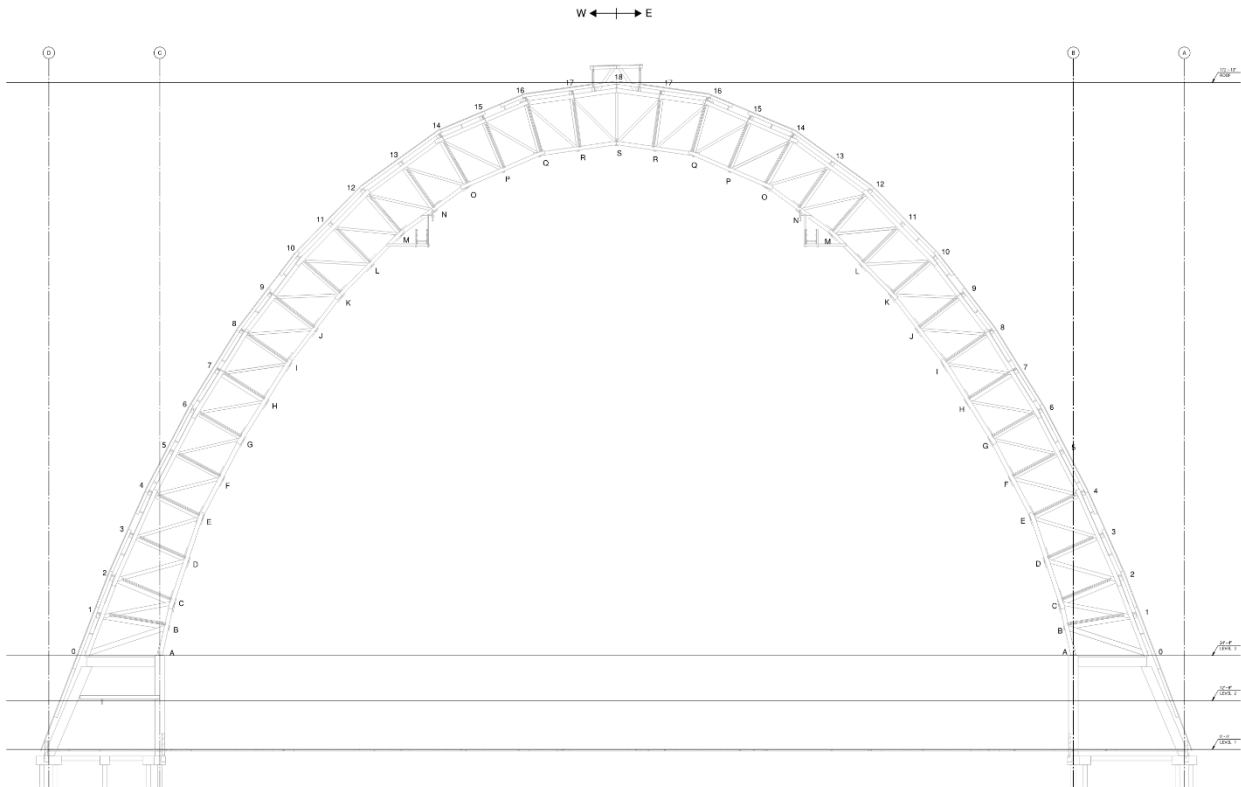

Figure 4. Typical truss elevation with labeled panel points.

1.2 Opinion regarding threat of collapse / partial collapse

Based on the progressing downward movement of the trusses observed in Hangar 3, there is a threat of partial collapse of the upper portions of the roof which may lead to progressive collapse of other portions of the truss. For this reason, temporary shoring has been installed within the most severely damaged zones to prevent any progressive collapse from occurring within the Hangar. The temporary shoring does not provide shoring to the upper most portion of the truss, since that zone needs to remain clear for accessibility by the movable access tower for the installation of truss repairs.

The following photos (Figure 5, Figure 6) demonstrate the severity of existing damage and the immediate danger of partial structure collapse.



Figure 5. Broken top chord near roof monitor at top of truss



Figure 6. Broken bottom chord near top of truss.

1.3 Data – summary of deflection and other measurements

Quantitative measurements of the truss deflections were taken from successive point cloud surveying of the hangar interior. The damage progression is shown in an example processed image from the 3D point cloud scans taken in 2014 and 2015 (Figure 7). In that figure, the black portion represents the actual position of Truss 22 between Panel Points Q-West and Q-East in 2014, while the red portion shows the position in August 2015. The measurements on the image show the increase in downward deflection between the surveys. A summary of deflections at Panel Point S indicate zones of damage concentration (Figure 8).

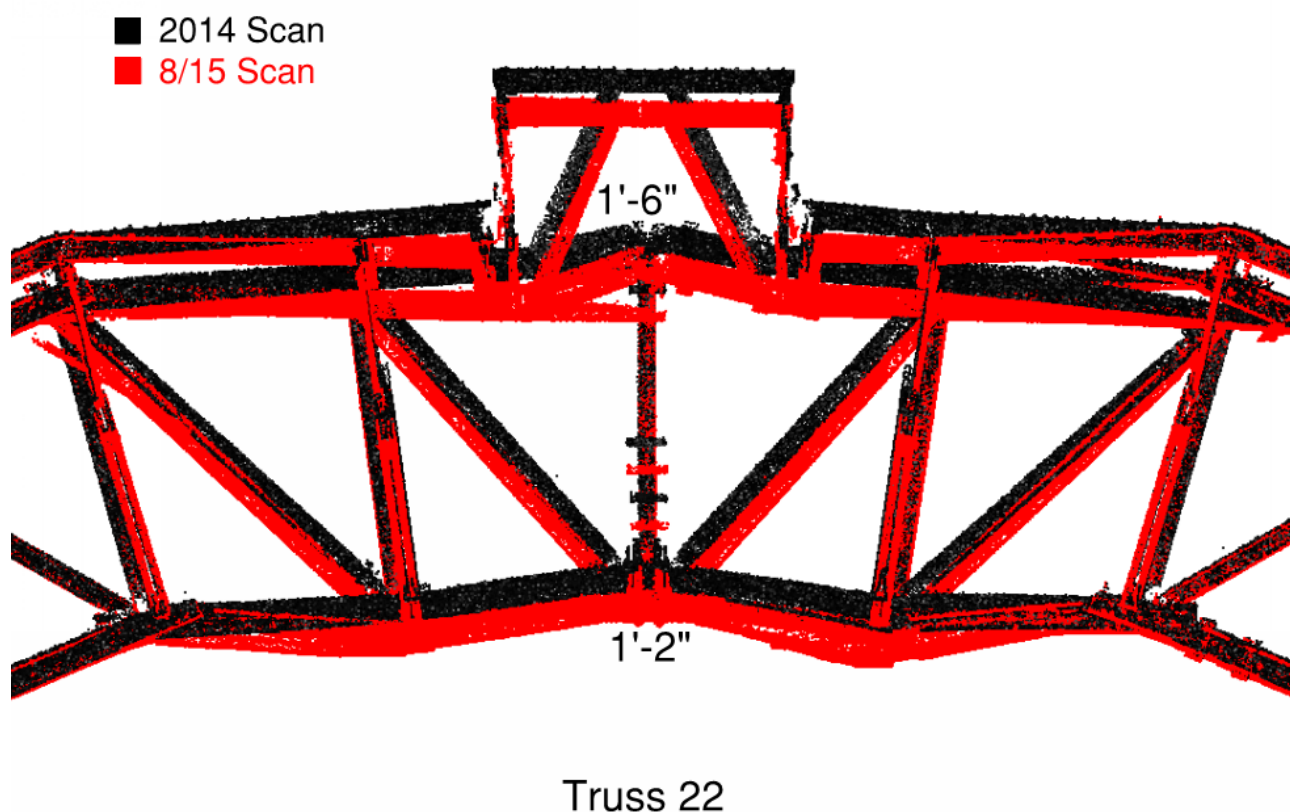

Figure 7. Approximately 18" of additional deflection observed between 2014 and 2015 point cloud surveying scan at top of truss.

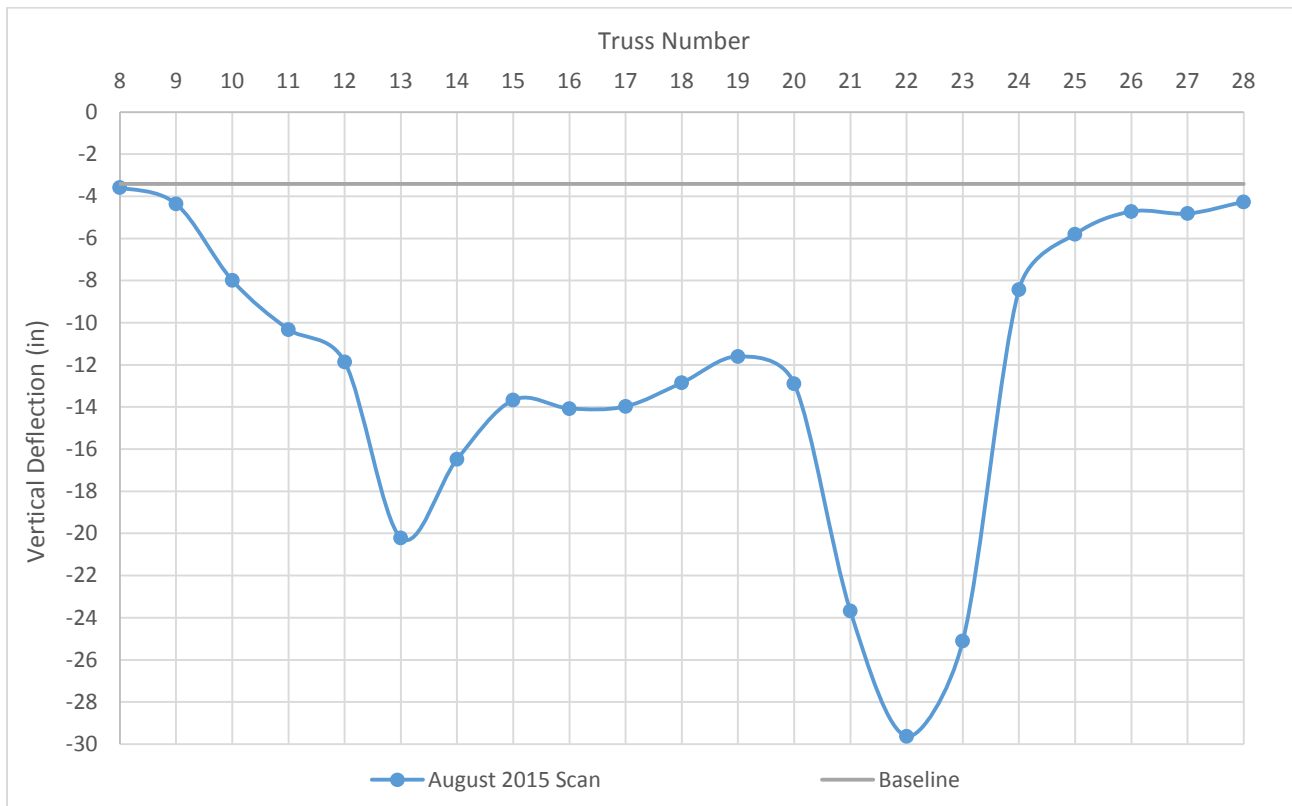

Figure 8. Deflections relative to baseline at Panel Point S.



2 Options for Emergency Repair considered

The selected scheme involving steel “exoskeleton” frames for jacking and temporary support of roof framing is described further in Section 3 of this narrative. The project team also explored several other options which were evaluated based on several factors including safety of workers during installation, construction sequence and schedule, engineering feasibility, cost, and effects to historic fabric.

For reference, the following is a list of alternatives considered:

- Jacking and shoring from traditional scaffolding: this scheme involved the installation of traditional scaffolding that would be capable of resisting additional loads due to jacking and shoring.
- Jacking and shoring from access tower: shoring and jacking from an access tower that extended to most of the severely damage zone.
- Wave Method: incrementally jacking from a smaller access tower starting at one end of the emergency repair zone and moving down (and possibly back) along the hangar deck.
- Exterior shoring: this scheme involved the installation of an exterior cable suspension system attached to the hangar roof. The cables would be supported by towers on the outside of the hangar and anchored to the ground. This type of temporary shoring system was used at the Tustin Hangars in Southern California.

In addition to selecting a method of installation, the project team also selected a target criteria for roof deflections. The number of exoskeletons and the number of jacks required depends on the amount of deflection to be reversed during the Emergency Repair process. However, full restoration back to the previous undamaged roof geometry may prove to be physically infeasible due to the complexity, risk, and timing involved in these operations due to existing field conditions. KPFF established the target deflection criteria shown in Table 1 and Figure 9 based on “Good”, “Better”, and “Best” scenarios.

Figure 9 was generated to illustrate the roof deflections (in blue) relative to a baseline that represents the average roof deflection at the trusses in the hangar that do not exhibit severe damage. The figure was used to compare the different deflection criteria options.

The project team selected the “Best-A” target criteria. Given the necessity of field adjustments due to the uncertain and changing existing conditions of the trusses and attachments, the project team may need to relax the acceptance criteria at specific locations. The end result could be a lower final outcome at some locations despite planning for “Best”. Choosing the “Best” target reduces the risk of ending up with final deflections below even the “Good” scenario. Achieving this highest objective endeavors to restore the trusses closer to their original design geometry. This reduces the risk of residual stresses and deflections in the truss members and resulting complications for the future seismic retrofit design of the hangar wood structure. Choosing a lesser criteria would have also introduced the risk of significant added cost for the future rehabilitation of Hangar 3. Targeting a lesser deflection target could lock in a less desirable pre-deflected shape, which may complicate installation of strengthening members or prompt another phase of jacking and shoring at a later time.



Table 1. Deflection criteria options considered.

	Good	Better	Best-A	Best-B
Truss and Roof Framing Maximum Deflection Relative to Average "Undamaged" Truss Elevation	± 8"	± 4"	± 1"	± 1"
Truss and Roof Framing Deflection Relative to Adjacent Trusses	± 4"	± 3"	± 2"	± 2"
Roof Monitor Deflection between Adjacent Trusses	± 4"	± 3"	± 2"	± 2"
Exoskeleton Locations	Trusses 11.5–23.5	Trusses 9.5–24.5	Trusses 9.5–25.5	Trusses 8.5–26.5
Number of Exoskeletons	13	16	17	19
Number of Exoskeleton Jacks	104	128	136	152
Number of Bays Where Jacking from the Shoring Tower is Required	0	0	3	1

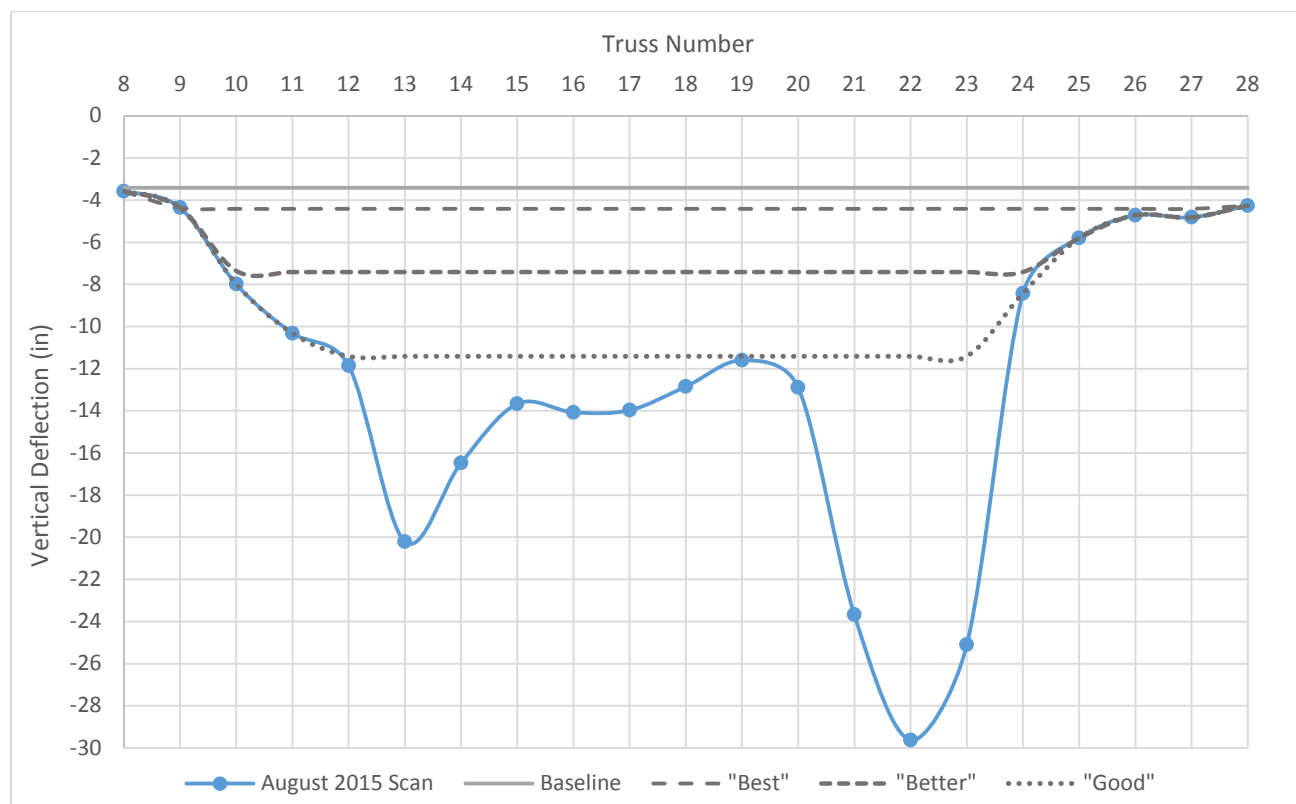

Figure 9. Hangar 3 Panel Point 18 Deflection with Deflection Criteria Options



Two options were studied by the design and construction team for the “Best” criteria. The difference between the two options is the sequence of construction and amount of Exoskeletons and jacks required. The first scenario (Best-A) utilizes both the access shoring tower and the Exoskeletons for jacking. Sequentially, the jacking at the trusses with the Exoskeletons are performed first, and then the shoring tower is moved to the ends of the severe damage zone to access the final 3 trusses (see Figure 10). In this scenario, an additional four Exoskeletons are required relative to the “Good” criteria.

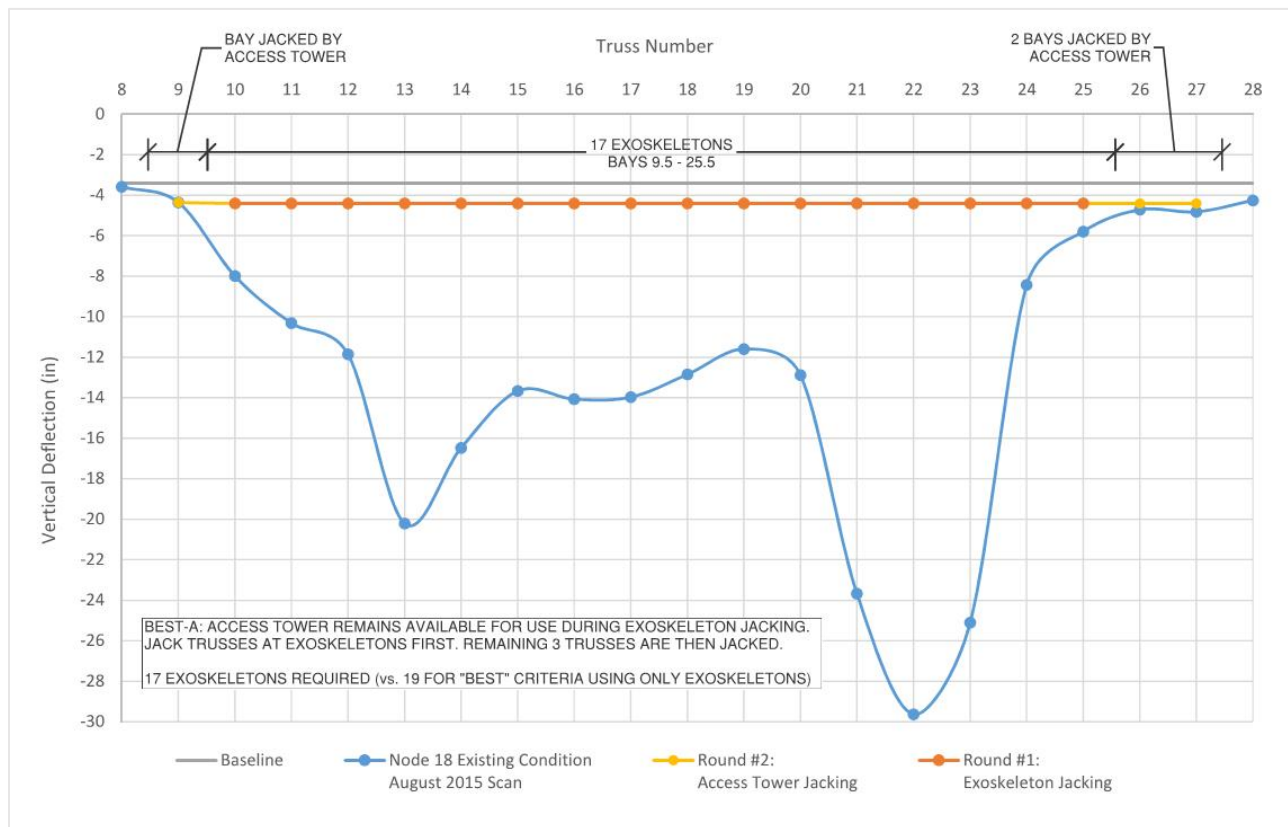

Figure 10. “Best-A” Target Deflection Criteria

The second scenario (Best-B) includes using only Exoskeletons for jacking trusses of significant deflection. In this scenario, two more Exoskeletons are required in addition to those required for the “Best-A” criteria, one between trusses 8 and 9, and one between trusses 25 and 26. Truss 27, which exhibits minor deflections, may need to be jacked from the access shoring tower to achieve the deflection criteria.

3 Emergency Repair Strategy for Selected Option

Step 1: Install temporary shoring braces to prevent full collapse of hangar (Figure 11 and Figure 12). The upper portion of the hangar remains unsupported and local damage progression and partial collapse of the upper zone is still possible.

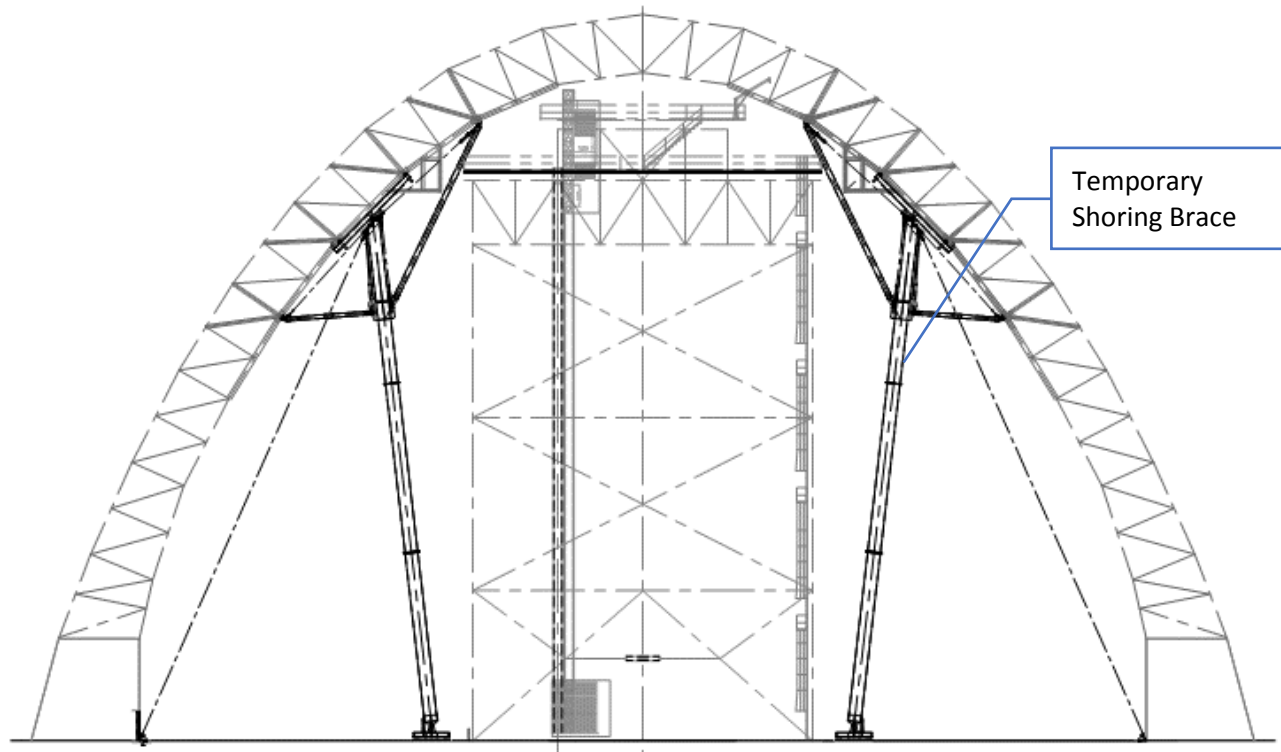

Figure 11. Temporary Shoring + Shoring Tower

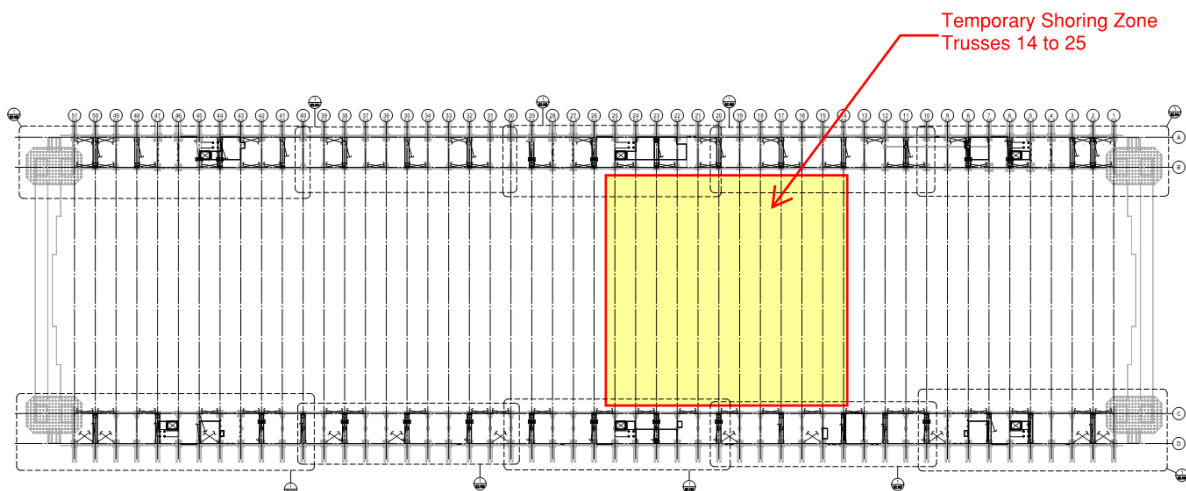

Figure 12. Zone of temporary shoring.

Step 2: Fabricate shoring tower and move shoring tower into the hangar to begin temporary support of the upper zone, and installation of support “Exoskeletons”. A computer rendering by Power Engineering Construction of these pieces is shown in Figure 13.

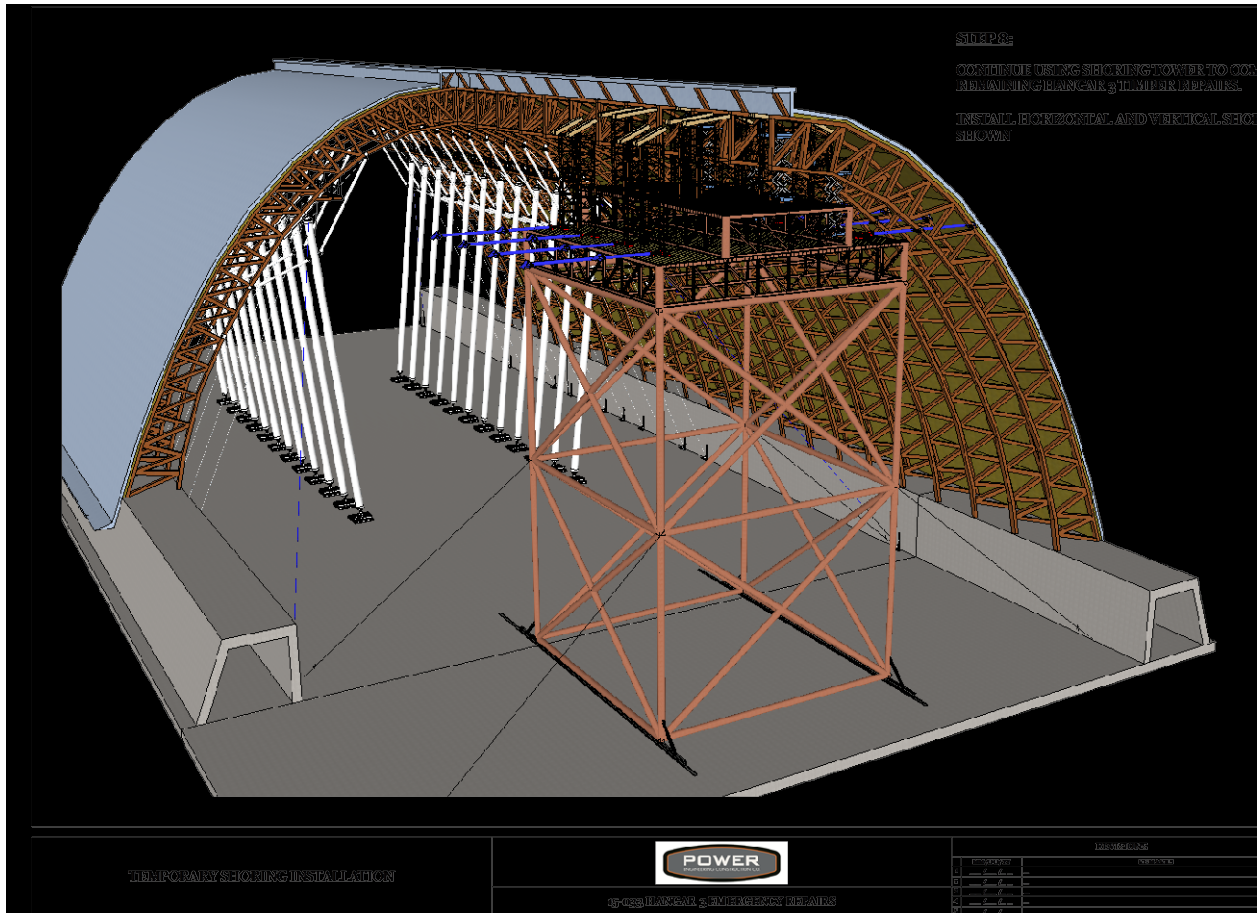

Figure 13. Isometric of Temporary Shoring & Shoring Tower

Step 3: Install steel truss support frames called “Exoskeletons” (Figure 14) in between existing wood trusses that have exhibited significant damage and deflection. The Exoskeletons are shop welded in segments which are field bolted together. The Exoskeletons are to be installed in the space between the existing trusses and will be attached to the existing trusses with bolts and steel plates (Figure 15).

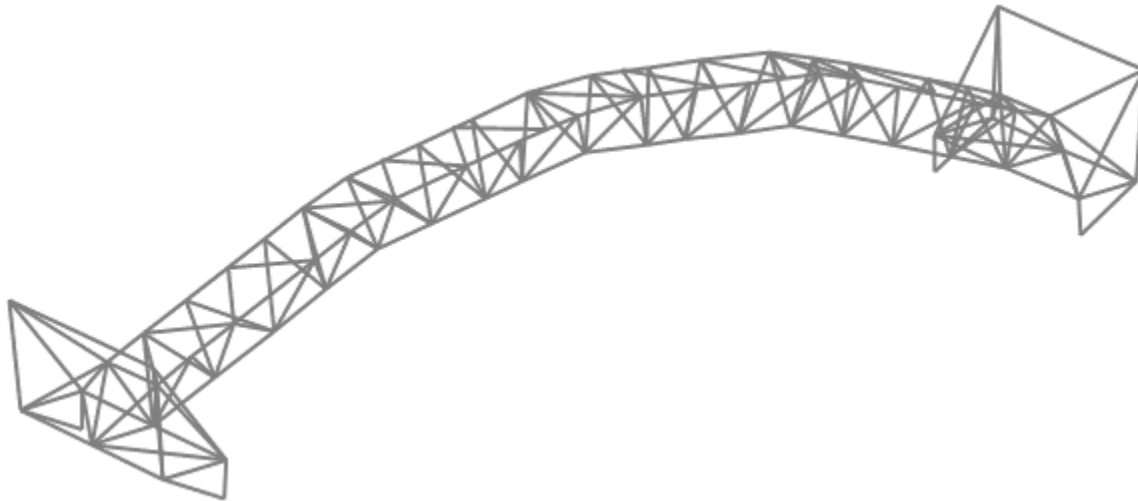

Figure 14. 3D Isometric of Steel Exoskeleton

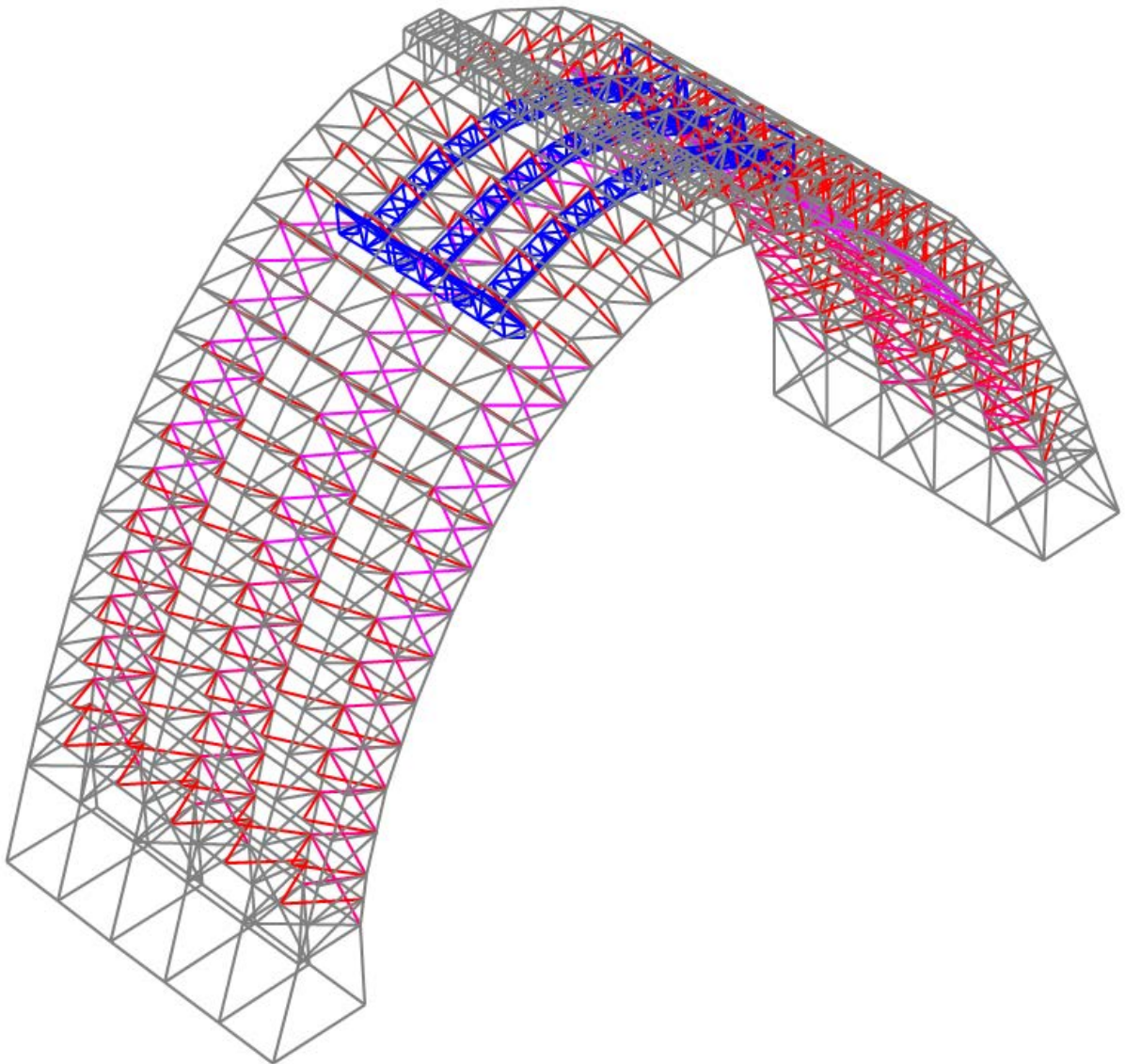

Figure 15. 3D Isometric of Exoskeletons Installed between Existing Wood Trusses

Step 4: Jack existing gravity framing from Exoskeletons to take gravity load off of the existing trusses and restore roof profile as close as possible to its undamaged state.

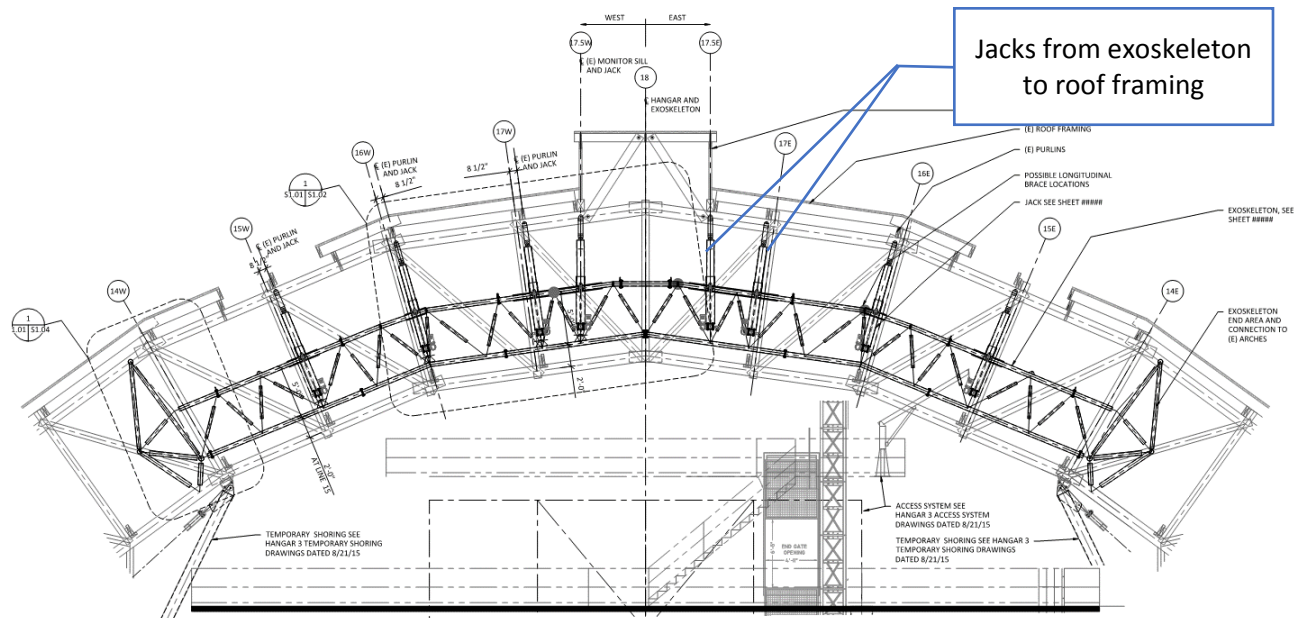

Figure 16. Exoskeleton Elevation (Preliminary Drawings)

Step 5: Perform emergency repairs to existing trusses and restore trusses as close as possible to original undamaged position from shoring tower.

Step 6: Remove jacks and Exoskeletons from the hangar. Remove connection steel plates except those portions that were used also to repair damaged existing timbers.

Step 7: Remove temporary shoring. Holes in existing concrete will be patched with a high-strength, non-shrink, non-metallic grout to match the color and texture of surrounding concrete as much as possible.

3.1 Portions that are permanent vs portions that are temporary

Temporary items include attachments and temporary wood repairs installed as part of the means and methods of construction. These items will be removed when practical in the construction sequence. Examples include the large temporary shoring tubes, tie rod bracing, jacks, access tower, and the steel Exoskeletons.

Permanent minor connection strengthening consists of stitch bolts at wood arch truss connection ends, and clamps at splits along the lengths of members (Figure 17). These have been installed in areas which require strengthening as part of the jacking sequence and emergency truss repair installation.



Figure 17. Example of new minor connection strengthening stitch bolts adjacent to existing angle clamp.

Permanent major connection strengthening consists of galvanized and painted cut HSS steel tubes, steel plates, and bolts (Figure 18). These items are currently being fabricated and coated and are pending installation. This type of repair will be installed in locations of severe damage within truss panel point connections, where the connection is damaged, but the timber is in fair condition outside the connection zone.

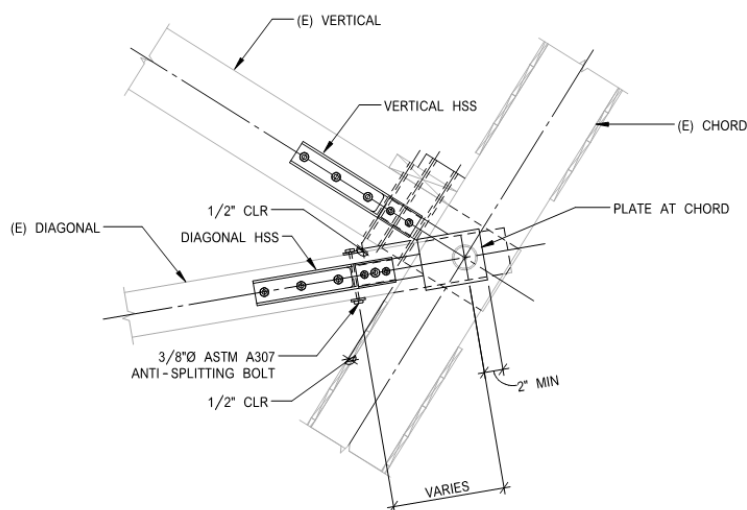

Figure 18. Permanent major connection strengthening.



3.2 Stamping of new wood members

New wood members installed in the emergency repairs project will be labeled in order to distinguish them from existing materials within the hangar. These members are stamped with a custom fabricated branding iron pyrography stamp with the text “2015/2016” using 3/4-inch tall lettering with the Arial typeface.

3.3 Why selected option is best for preservation

The selected emergency repair strategy is best for preservation because we are achieving the best restoration of the hangar ridge line deflection with the intent of replacing damaged truss members in-kind with timber similar to the original truss configuration. The project team decided to pursue the “Best” deflection criteria which targets restoration of the truss and roof framing nearest to the average “undamaged” truss elevation. In the event that “Best” is unachievable due to field conditions, a lesser criteria can still be achieved which is acceptable from a structural and architectural standpoint.

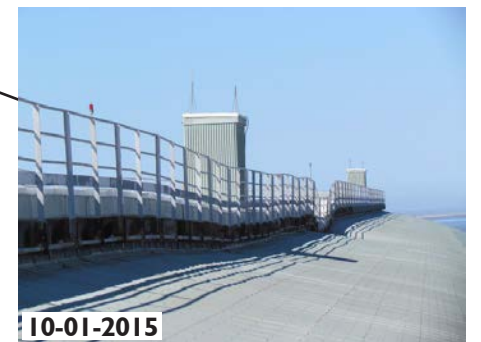
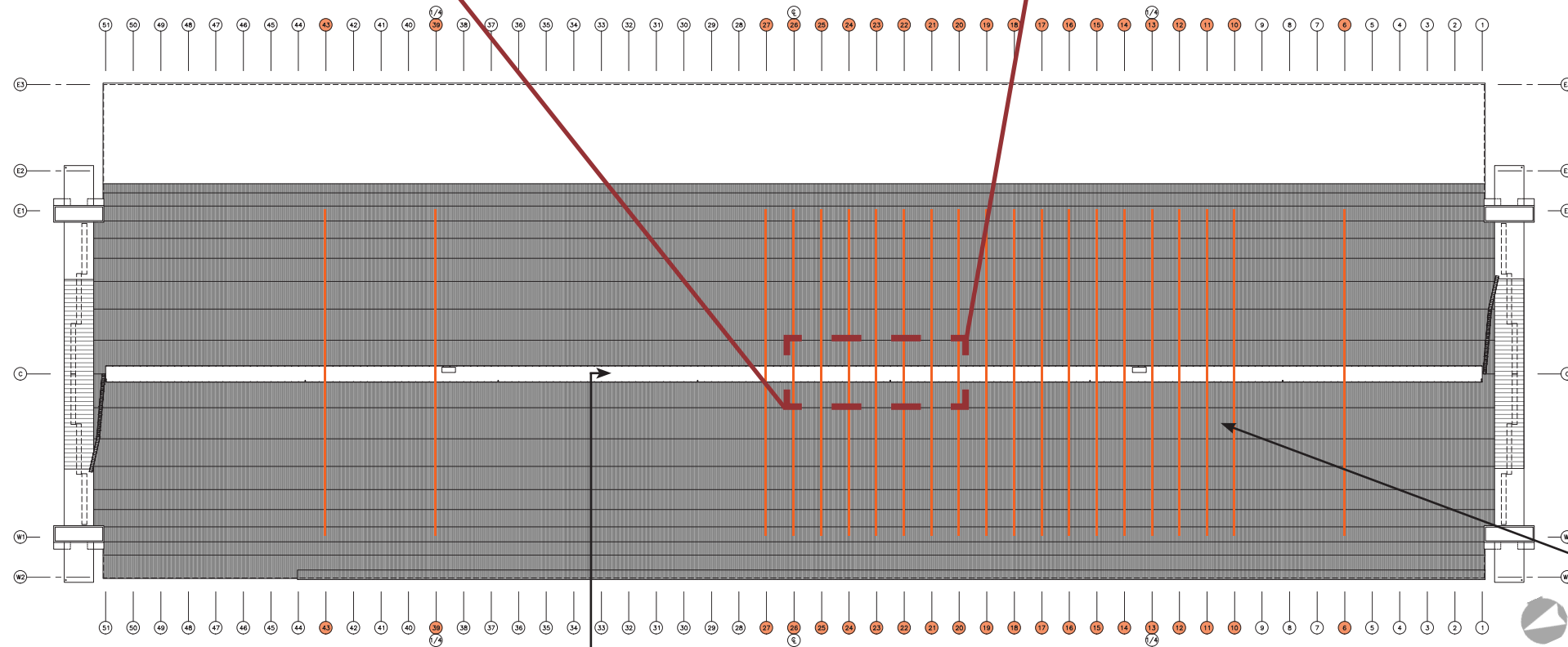
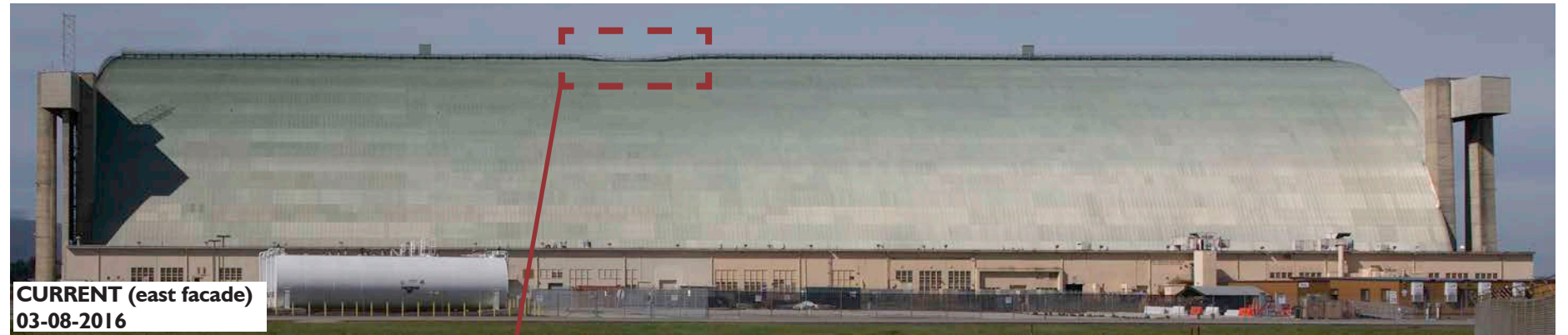

EXTERIOR CONDITIONS

Roof plan from Hangar 3 Existing Roof Plan by Page & Turnbull on 03-30-2015, with photographs by Erin Ouborg, Steven Aiello, and Mark Citret on behalf of Page & Turnbull, as well as photographs from Engineer's Field Report by KPFF on 06-30-2015

KEY
— Location of trusses for emergency repairs

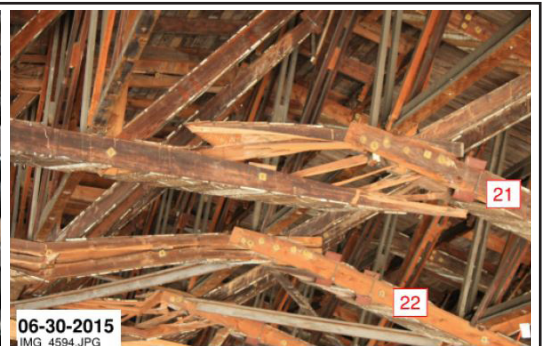
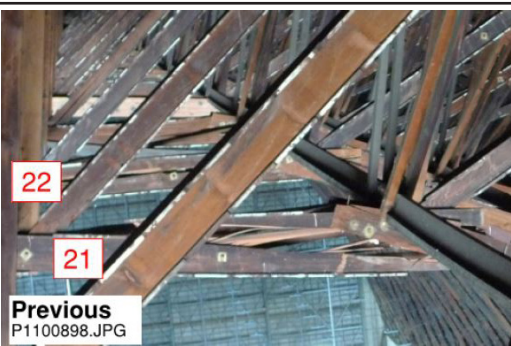
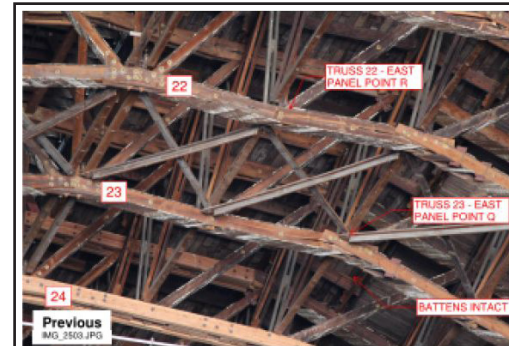
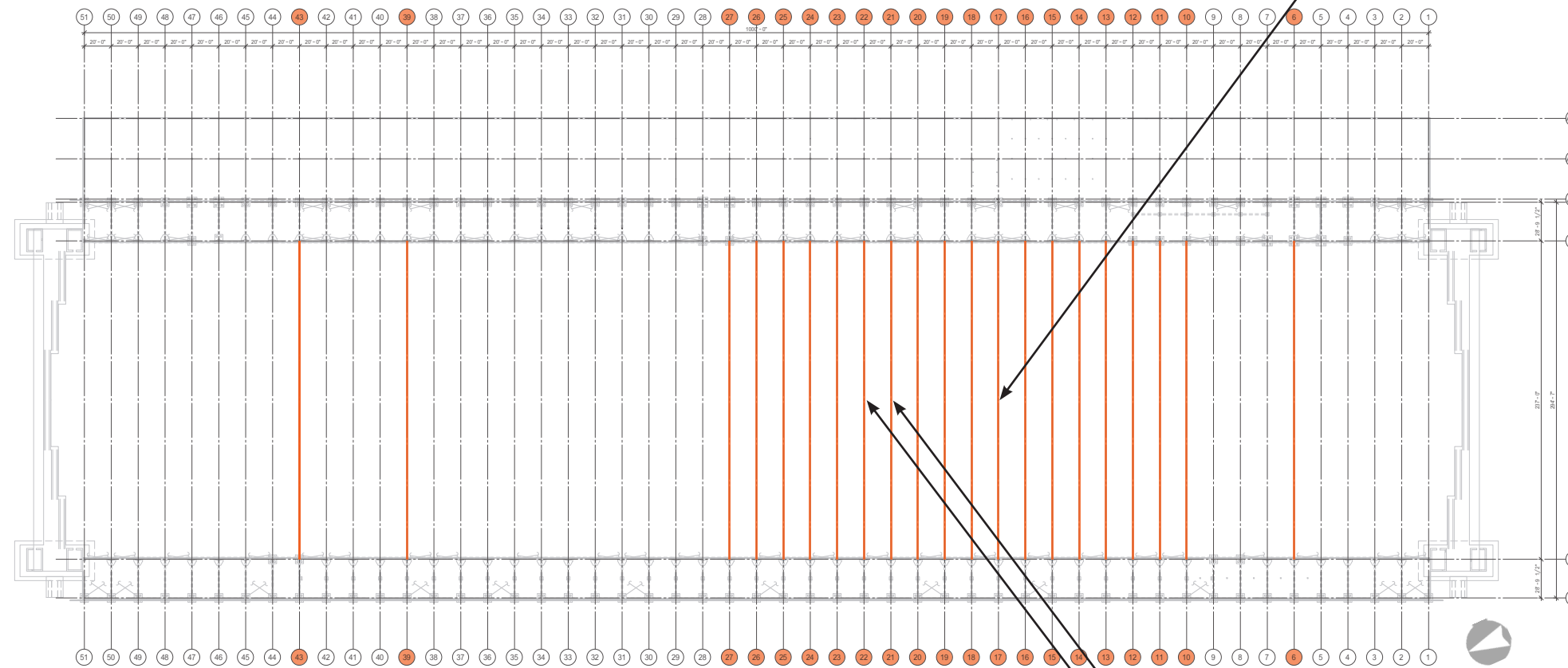
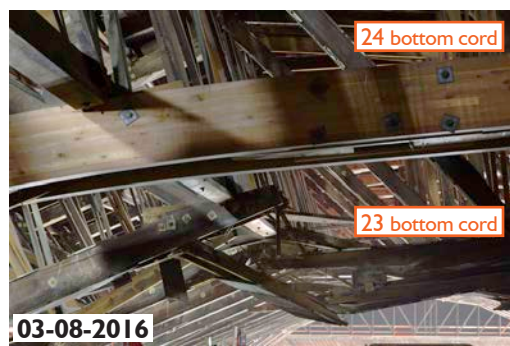
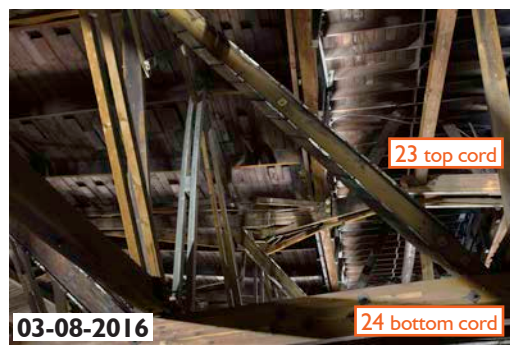
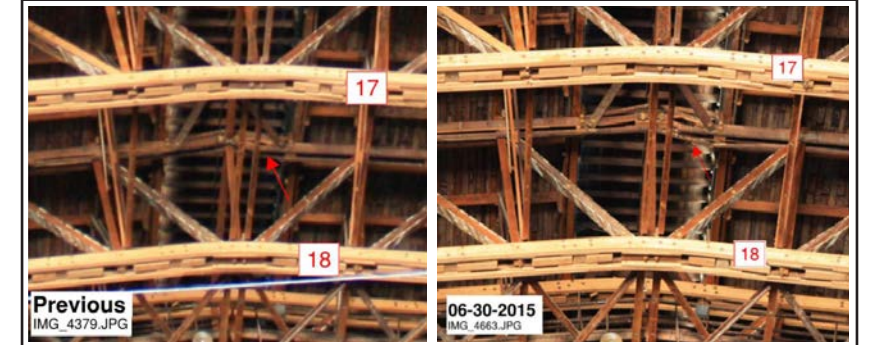

INTERIOR CONDITIONS

Foundation Plan from Moffett Federal Airfield - Hangar 3 Emergency Truss Repairs Set, Permit Revision 1 by KPFF on 03-17-2016, with photographs by Erin Ouborg and Mark Citret on behalf of Page & Turnbull, as well as photographs from Engineer's Field Report by KPFF on 06-30-2015

KEY
 — Location of trusses for emergency repairs

- b. REMOVE THE ACCESS SYSTEM UNDER THE LEAST DAMAGED TRUSSES AT ONE END OF WHERE THE EXOSKELETONS WILL BE INSTALLED.
- d. INSTALL LATERAL BRACING BETWEEN HANGAR TRUSSES ABOVE ACCESS SYSTEM.
- c. INSTALL TEMPORARY POST SHORING BETWEEN THE ACCESS SYSTEM DECKS AND THE ROOF PURLINS.

1. INSTALL TEMPORARY SHORING BETWEEN HANGAR TRUSSES ABOVE ACCESS SYSTEM.



THE FOLLOWING IS THE CURRENT GENERAL REPAIR PROCEDURE. POWER WILL DEVELOP DETAILED PROCEDURES. THIS GENERAL PROCEDURE MAY CHANGE AS THE REPAIR METHODS AND DESIGNS ARE REFINED, OR IF THE EXTENT AND MAGNITUDE OF HANGAR DAMAGE INCREASES.

EXAGGERATED DEFLECTED SHAPE AT HANGAR CENTERLINE FROM POWER AS OF AUGUST 4, LOCATIONS OF THE HANGAR STRUCTURE ARE 34" LOWER IN ELEVATION THAN THAT SHOWN ON THE DESIGN DRAWINGS WITH AN ESTIMATED DAMAGE DEFLECTION OF AROUND 30". REFER TO POWER ENGINEERING CONSTRUCTION'S AUGUST 4 EMAIL. TRUSS ELEVATIONS SHALL BE MONITORED AND REPORTED THROUGHOUT THE REPAIRS BASED ON THE REPAIR GEOMETRY CRITERIA. SEE KPFF REPAIR DRAWINGS.

REPAIR APPROACH:

1. INSTALL TEMPORARY SHORING SYSTEMS BETWEEN THE SLAB AND HANGAR STRUCTURE TO SHORE THE LOWER TWO THIRDS OF THE HANGAR STRUCTURE. REFER TO THE DRAWINGS: HANGAR 3 TEMPORARY SHORING, LIFTECH, JULY 28, 2015, REVISED AUGUST 2a AND 2b, 2015.
- 2a. INSTALL LATERAL BRACING AND 2c. TEMPORARY POST SHORING.

- 3a. AT THE TRUSSES WITH SIGNIFICANT DAMAGE, INSTALL STEEL EXOSKELETON TRUSSES BETWEEN THE HANGAR TRUSSES TO REPLACE THE STRENGTH OF THE HANGAR TRUSS STRUCTURE.

- a. INSTALL LATERAL BRACING FROM THE COMPETENT HANGAR TRUSS UP TO THE EXOSKELETON AREA. THIS BRACING IS IN THE LONGITUDINAL DIRECTION OF THE HANGAR. SEE _____
- b. POSITION THE ACCESS SYSTEM UNDER THE LEAST DAMAGED TRUSSES AT ONE END OF WHERE THE EXOSKELETONS WILL BE INSTALLED. SEE _____
- c. INSTALL TEMPORARY POST SHORING BETWEEN THE ACCESS SYSTEM DECKS AND THE ROOF PURLINS.
- d. INSTALL LATERAL BRACING BETWEEN HANGAR TRUSSES ABOVE ACCESS SYSTEM.

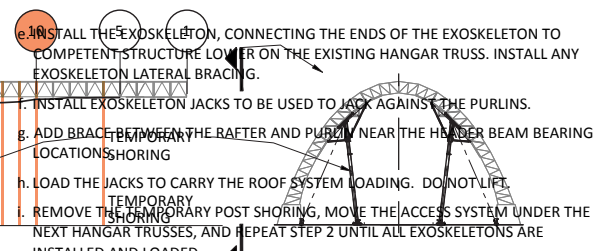

3. INSTALL LATERAL BRACING AT HANGAR TRUSS LOCATIONS THAT ARE BEYOND THE EXOSKELETON LOCATIONS BUT WILL ALSO BE RAISED.
4. REMOVE DAMAGED PORTIONS OF THE HANGAR TRUSS AND DISCONNECT THE HANGAR TRUSSES FROM THE ROOF. START AT THE HANGAR TRUSSES WITH THE LEAST DAMAGE.

CONTINUED ON SHEET G3.02

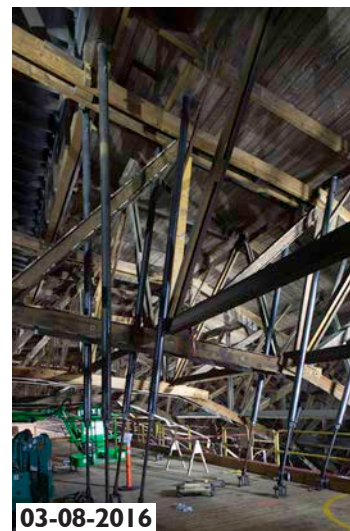
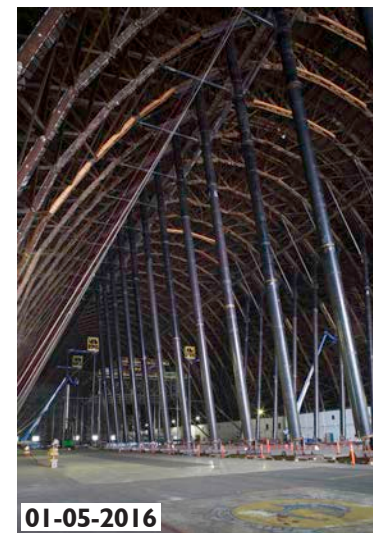
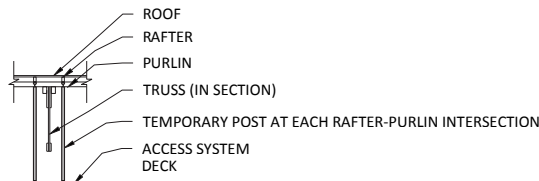

2e, 2g, and 2h. INSTALL EXOSKELETONS AND PURLIN BRACES, RELIEVE TRUSS LOADING WITH JACKS IN EXOSKELETONS IN PROGRESS

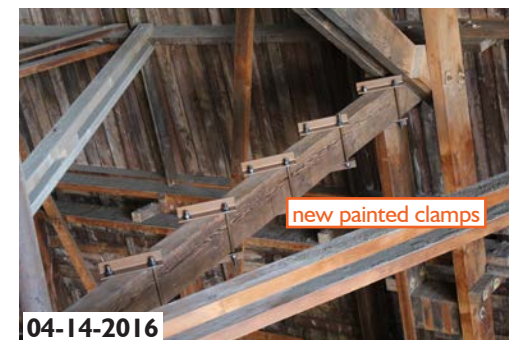
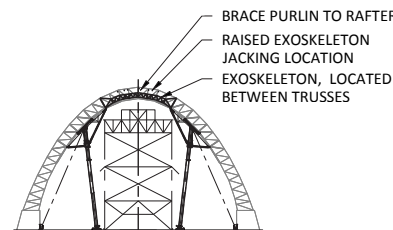
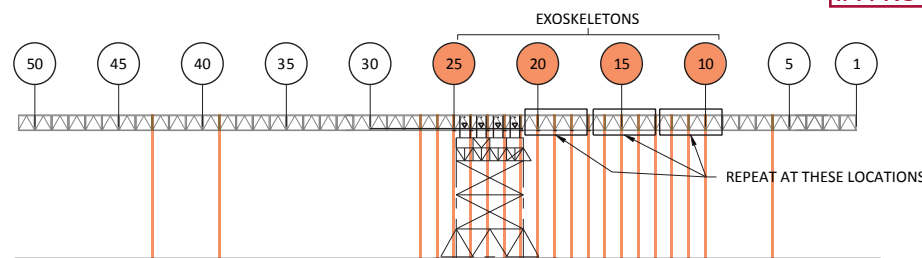

REPAIR PROCEDURES

Elevations from Hangar 3 Shoring and Access System drawings by Power and Liftech on 10-06-2015, with photographs by Erin Ouborg and Mark Citret on behalf of Page & Turnbull

KEY
— Location of trusses for emergency repairs

Original border size 525 x 812 mm
344 - 20th STREET SUITE 360, Oakland, CA 94612, 510.822.5606

3. INSTALL LATERAL BRACING BEYOND EXOSKELETON LOCATIONS

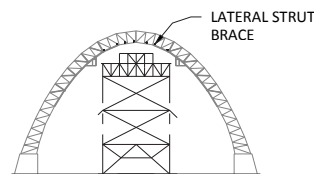
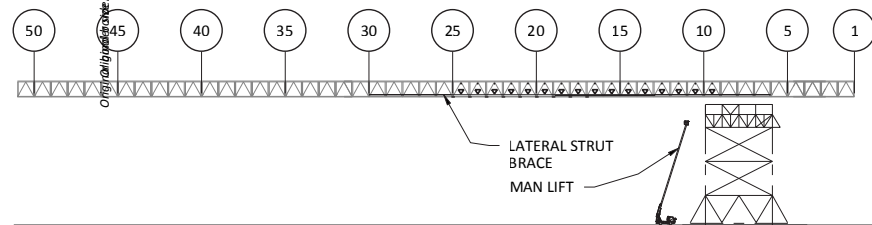

8. ADDITIONAL ROOF ELEVATION ADJUSTMENT BY SHIMMING - AS REQUIRED

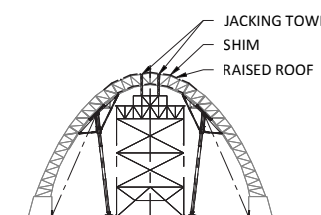
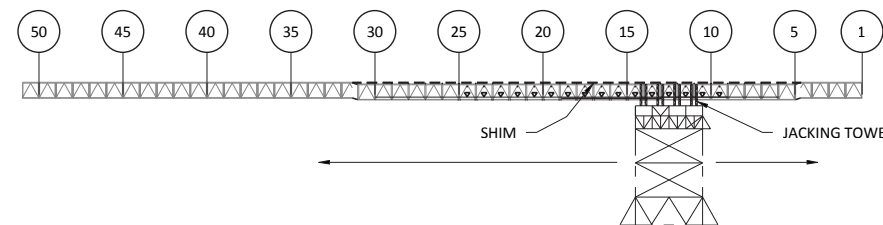

4. REMOVE HANGAR TRUSS DAMAGE AT EXOSKELETONS, AND DISCONNECT HANGAR TRUSSES FROM THE ROOF.

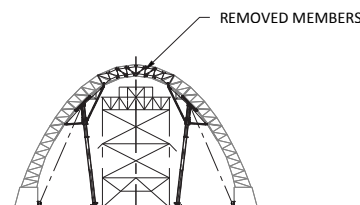
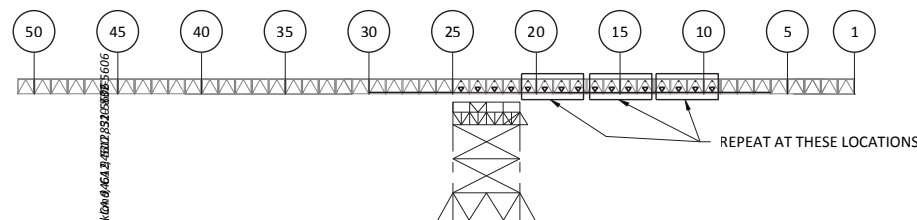

9. REMOVE LATERAL BRACING AND TEMPORARY SHORING

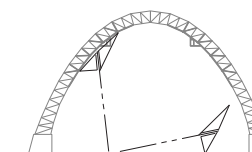
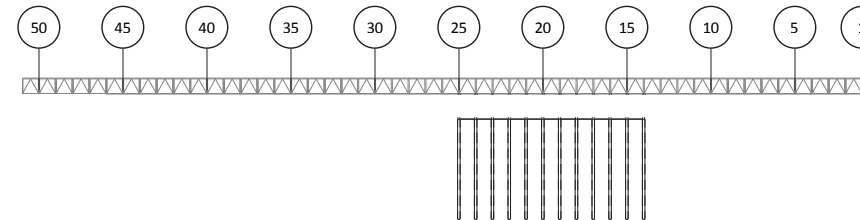

5. RAISE ROOF AT EXOSKELETONS

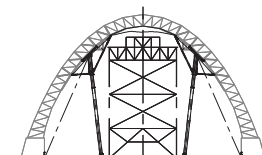
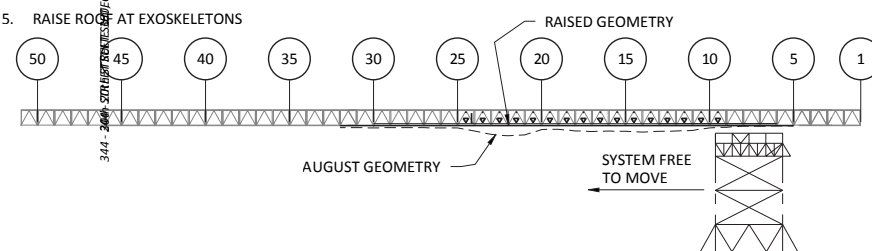

6. REPAIR OR REBUILD HANGAR TRUSSES AT RAISED LOCATIONS

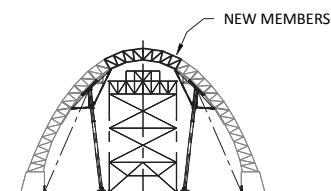
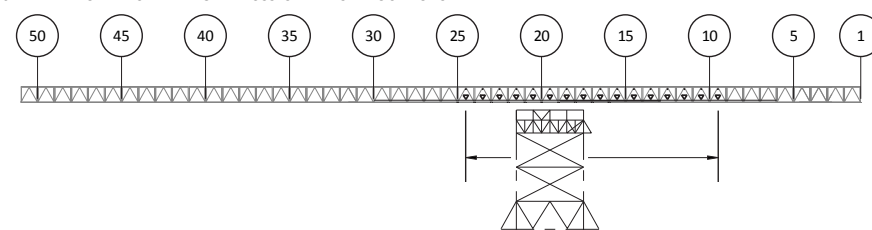

7. RAISE AND REPAIR OTHER LOCATIONS - AS REQUIRED

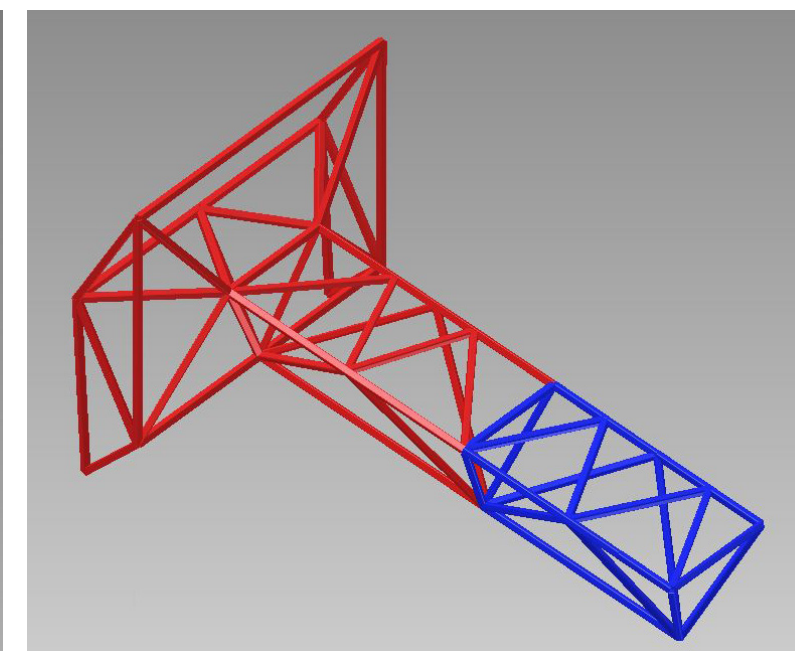
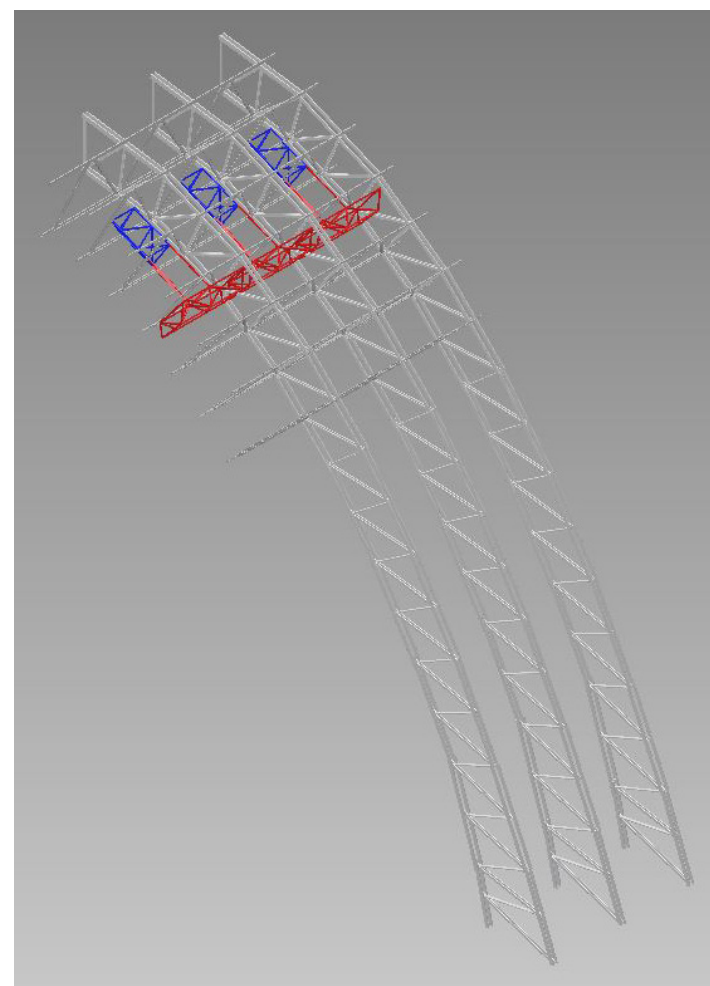
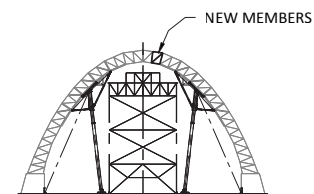
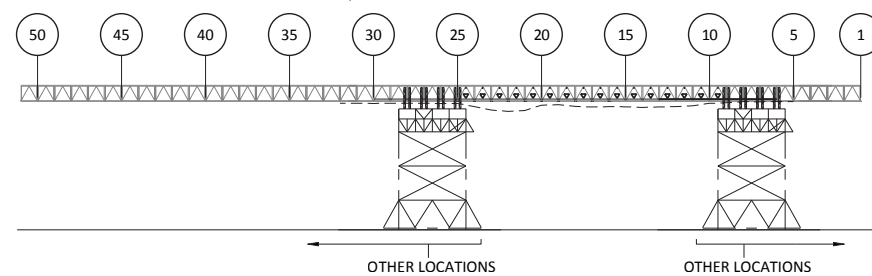

3D Model of Exoskeleton (colors are for visual aid only)

Checked

Checked
Checked

REPAIR PROCEDURES (REMAINING STEPS)

Elevations from Hangar 3 Shoring and Access System drawings by Power and Liftech on 10-06-2015, with 3D Model of Exoskeleton by Liftech on 10-06-2015

A.3 - Due Diligence Investigations

CONSTRUCTION

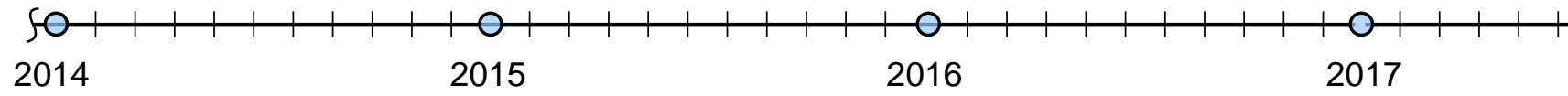
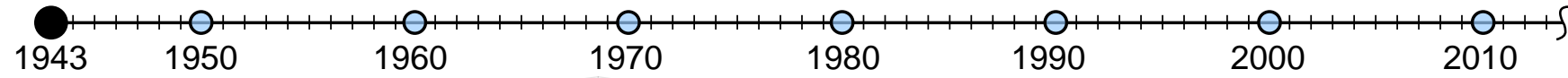

DRAFT - 7/6/2017
SED

- Built in 1943 to house the Navy LTA (Lighter than Air) program, which used blimps to provide a network for coastal submarine patrol
- Built with wood to save steel for the war effort
- Intended to be semi-permanent wartime structures

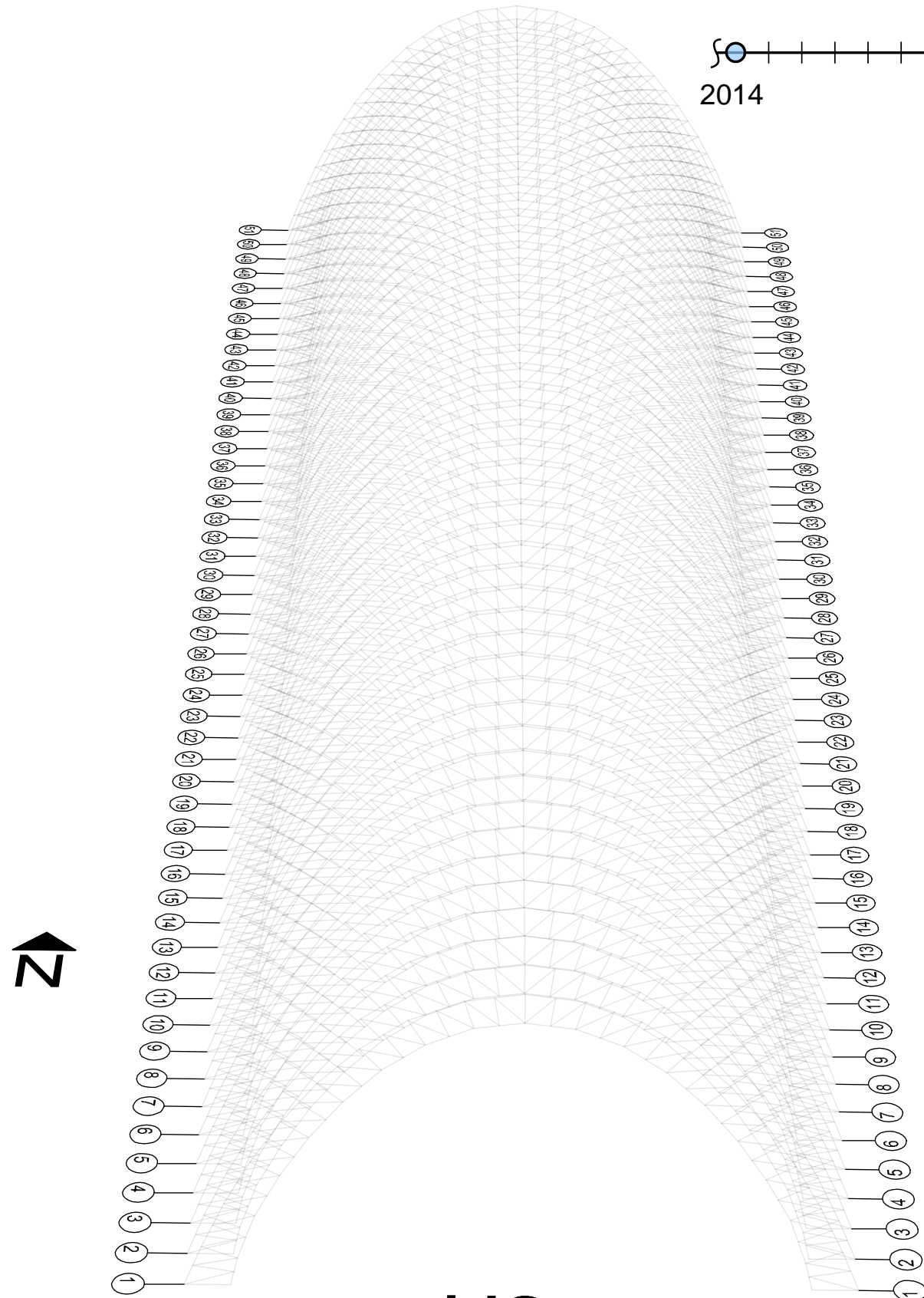

H3

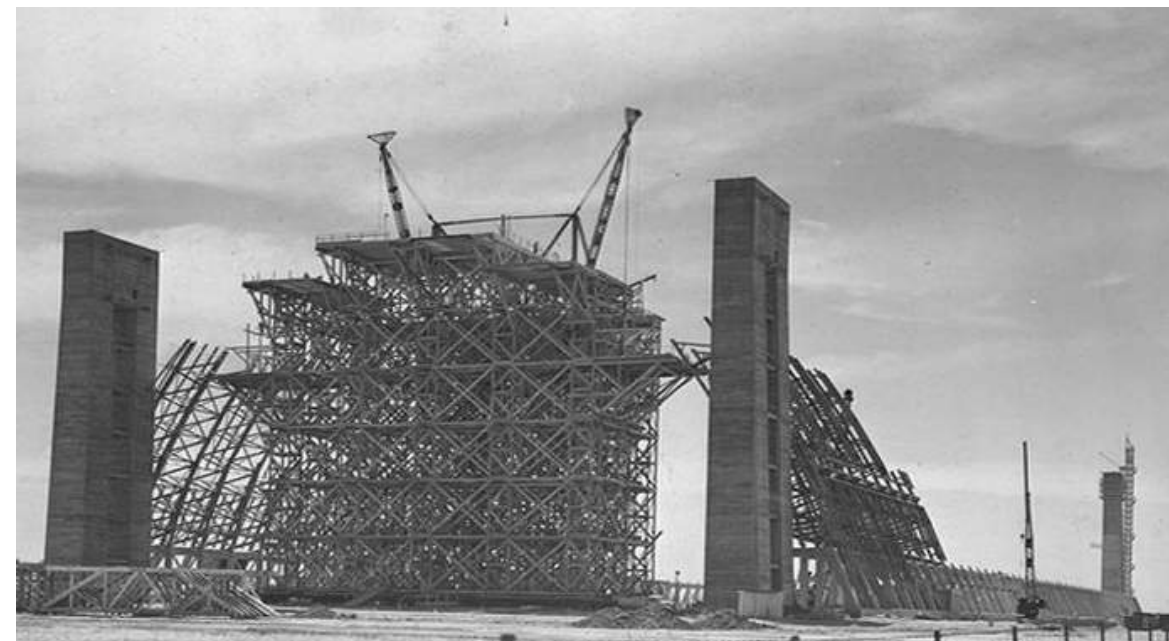

*Hangar 3 under construction
-US Navy Historic Photos*



*Pre-assembled truss panels awaiting erection
-US Navy Historic Photos*



*Hangars 2&3 under construction
-US Navy Historic Photos*

EAST SHED ANNEX

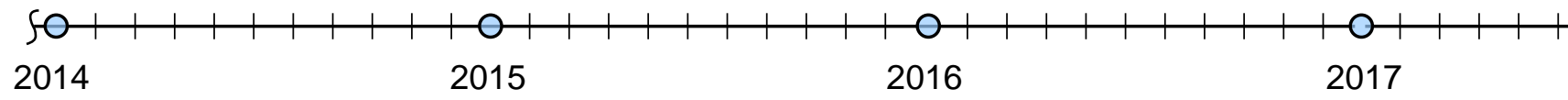
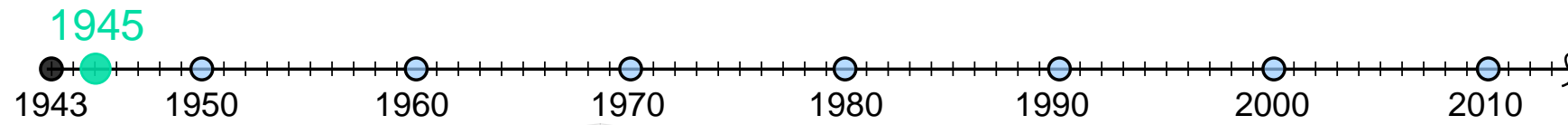

Legend

■ East Annex Shed

- After WW2, the east shed was expanded to support Heavier than Air (H.T.A.) operations

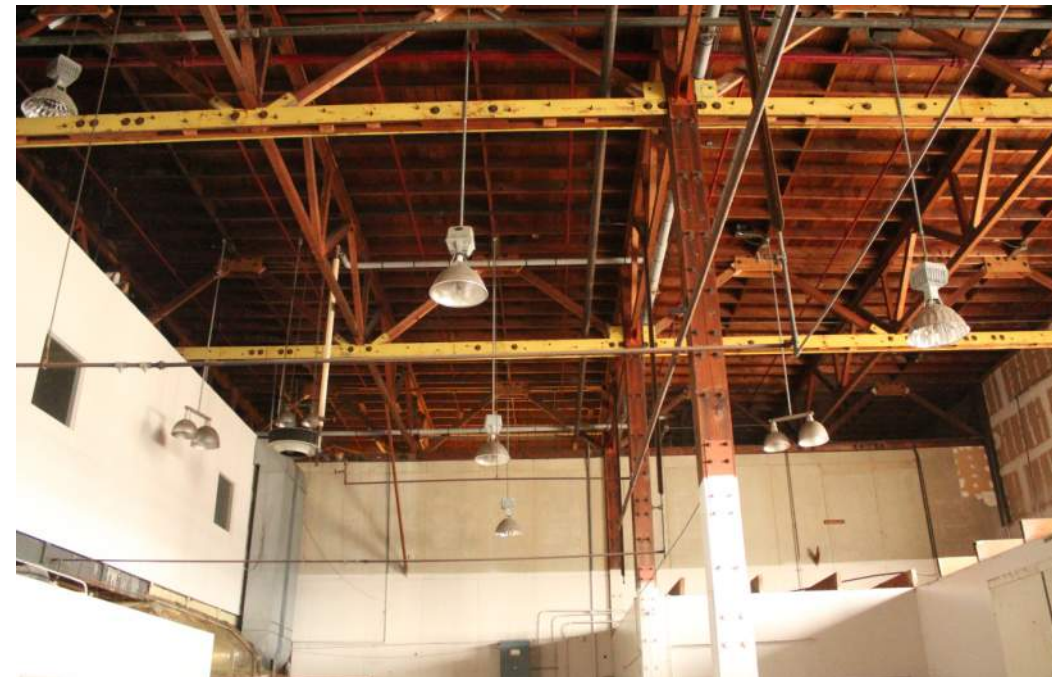

Interior view of Hangar 3 East Shed Annex

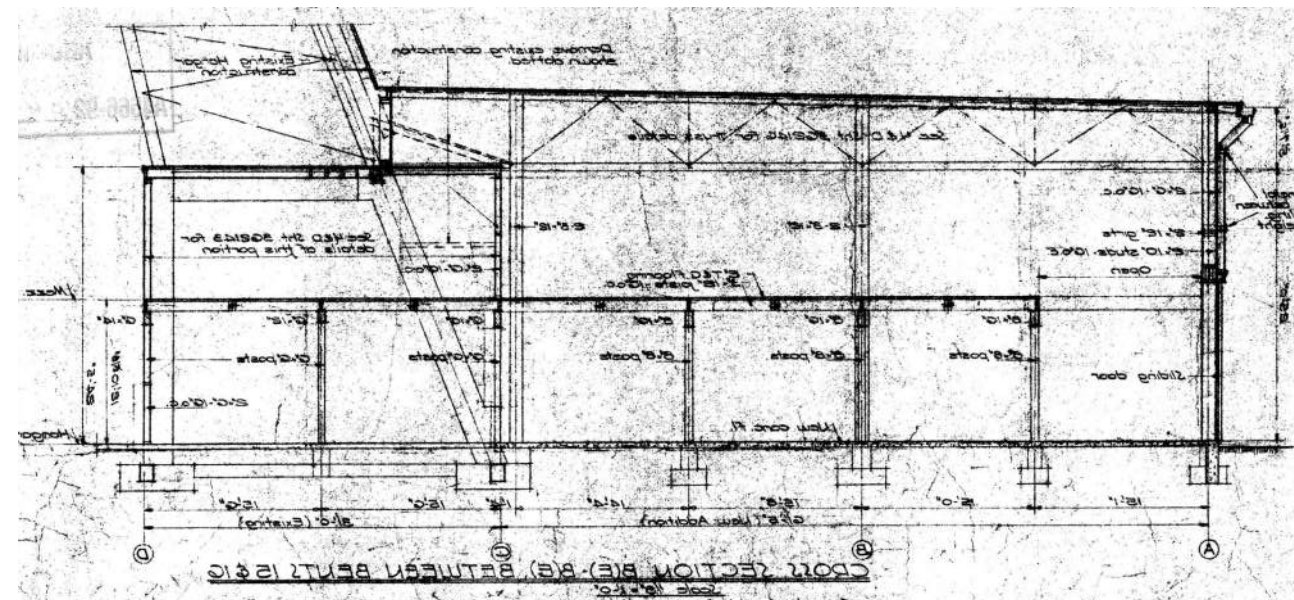

Elevation view of Hangar 3 East Shed Annex

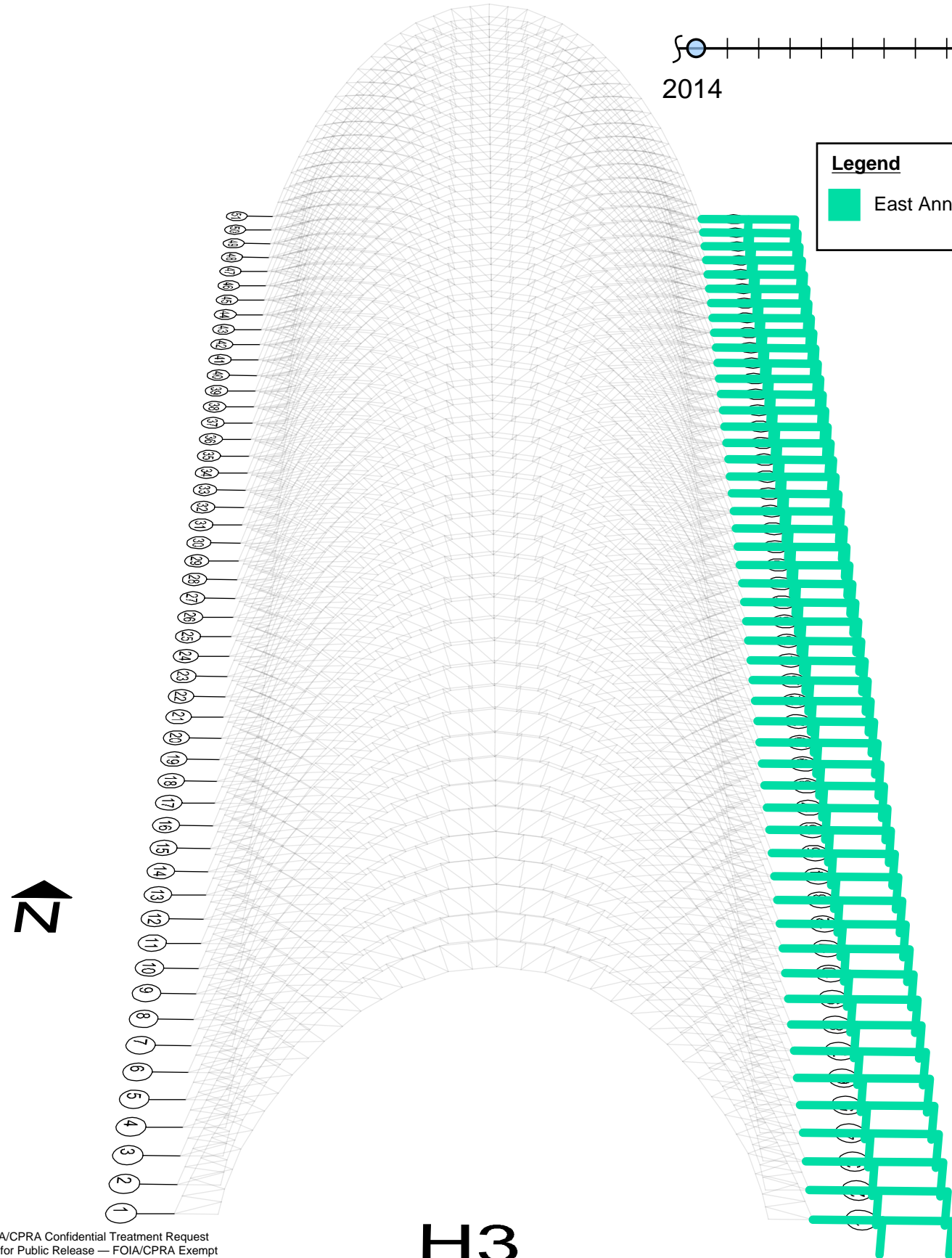

H3

BATTEN STRENGTHENING

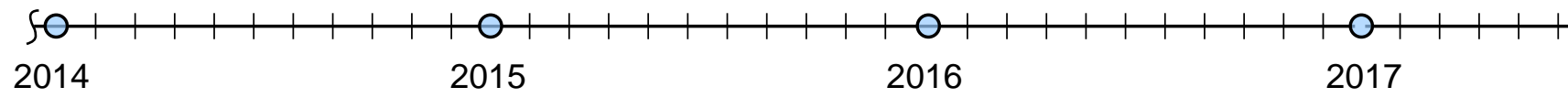
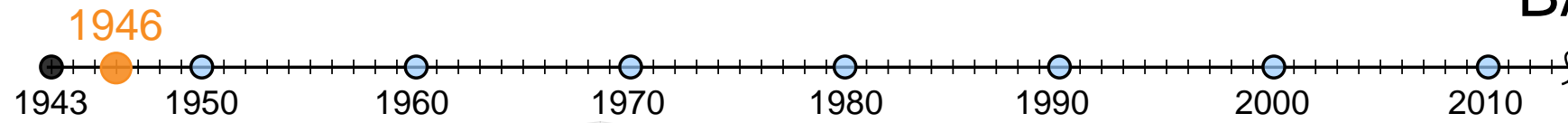

DRAFT - 7/6/2017
SED

Legend

Batten Strengthening

- Battens were added to bottom chords, and some top chords and diagonals to increase stability and help prevent buckling
- Upgrade was intended to increase the longevity of the temporary structure
- Battens added to **2244** members per hangar
- Batten wood was treated with a mixture of borax, white lead, and linseed oil paint.
- "These battens, with a few additional bolts and blocking at the chord splices, are the principle measures taken in strengthening and making permanent these wood buildings."
"Strengthening of LTA Hangars, Naval Air Station, Moffett Field, California", J.S. Marsh, 1946

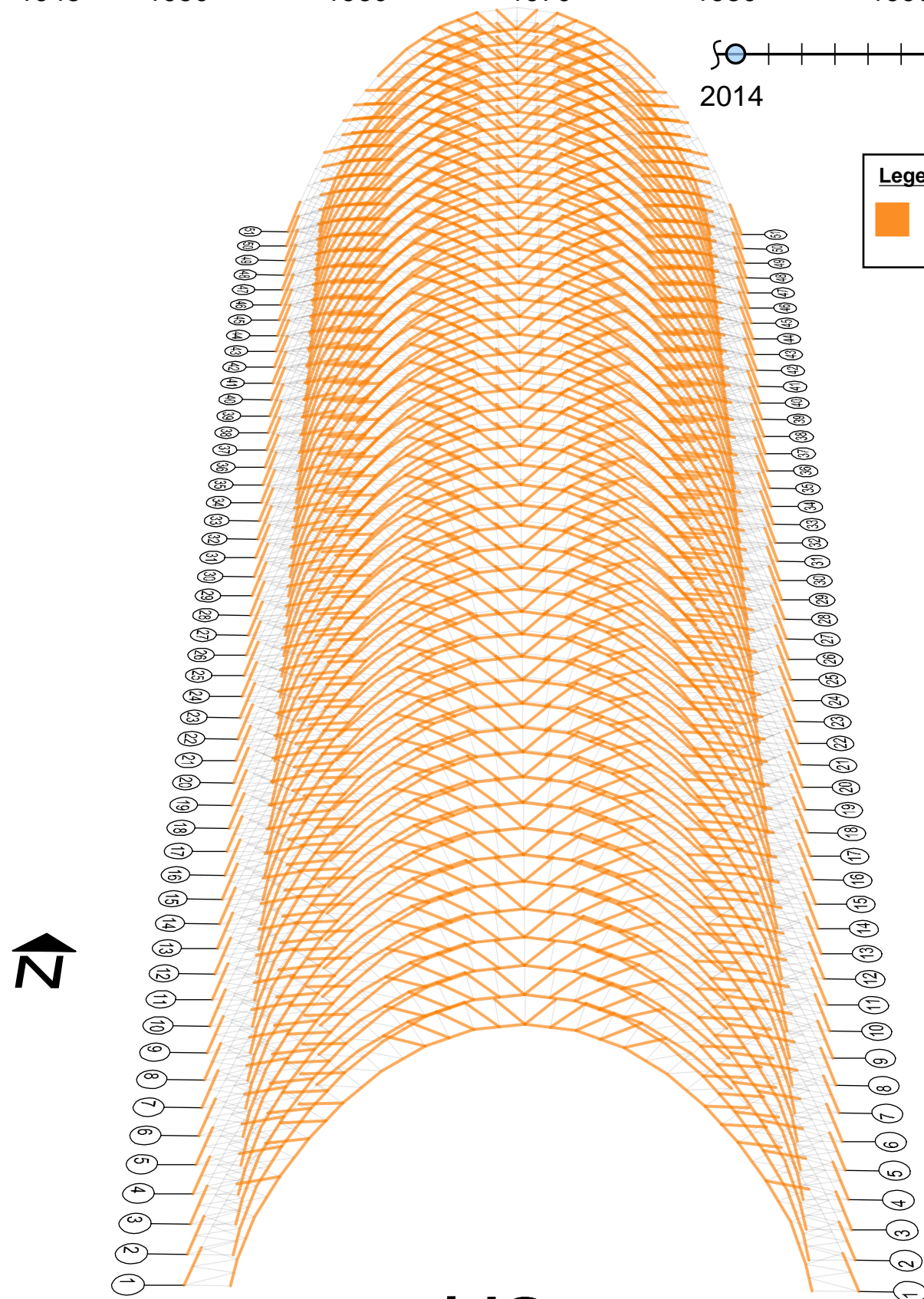

Typical chord member with battens

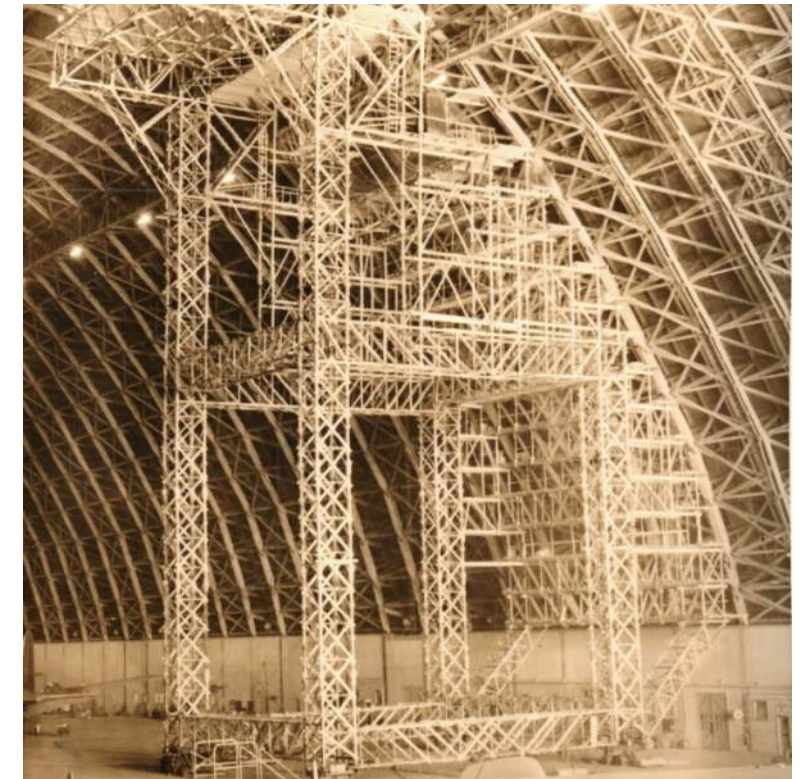

Rolling scaffold used to install battens
- Seabees Historic Photos

KNEE BRACES

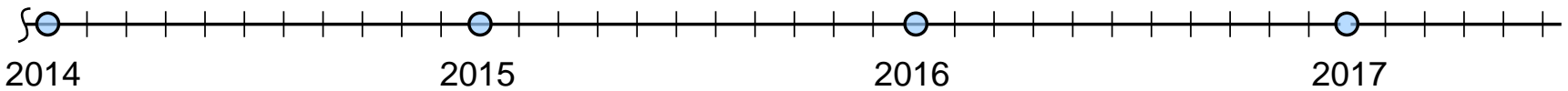
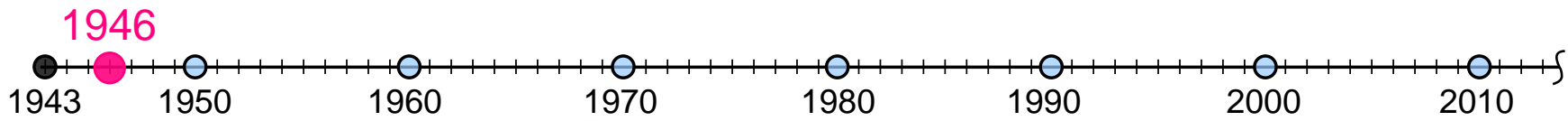

DRAFT - 7/6/2017
SED

Legend

Knee Braces at Vertical Web Members

- Knee-braces were added to reduce the unbraced length of certain vertical web members
- These braces were part of the 1946 strengthening measures described by J.S. Marsh.
- Knee braces added to **700** vertical web members

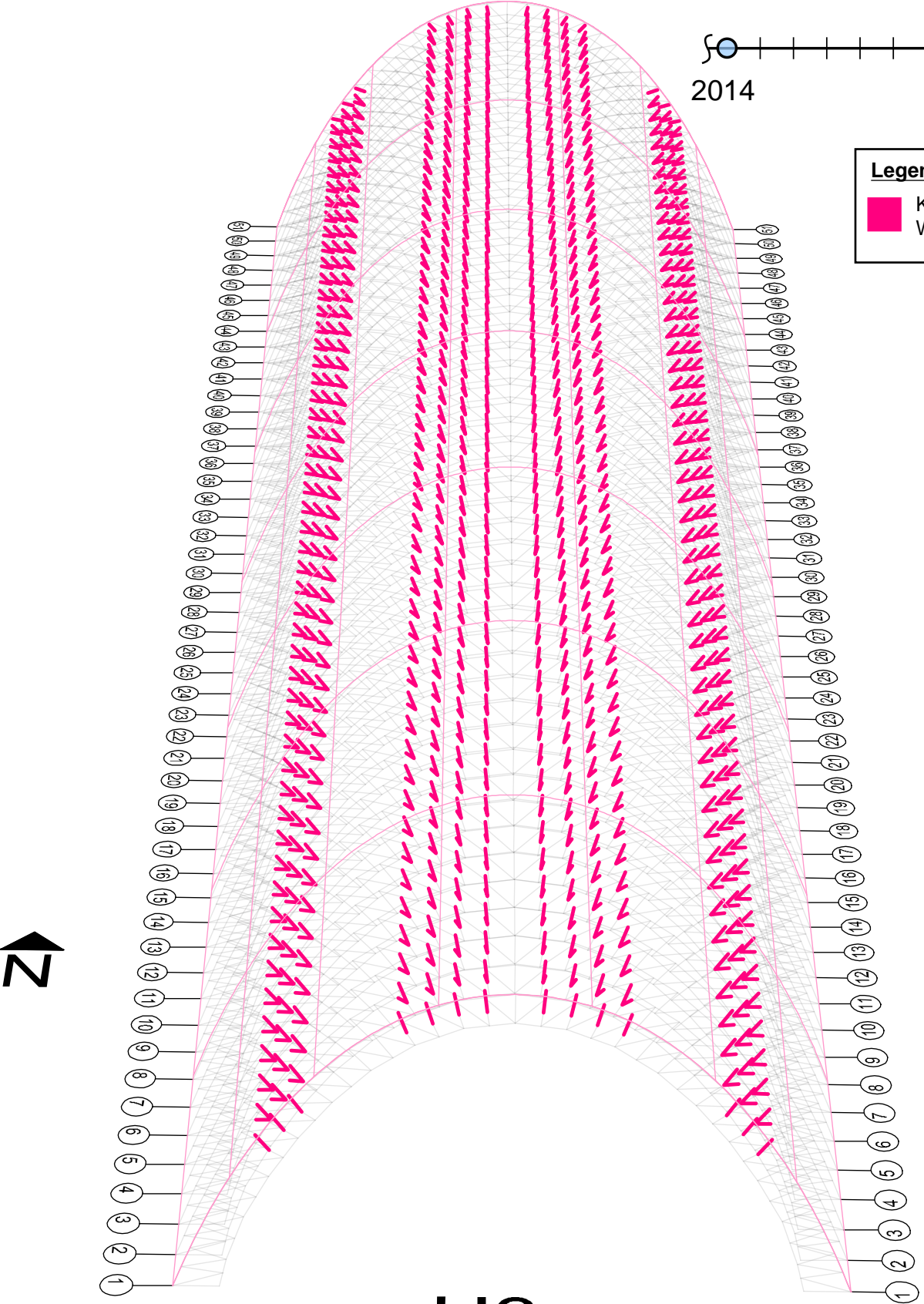

Typical vertical web member with added knee-braces

RE-ROOFING

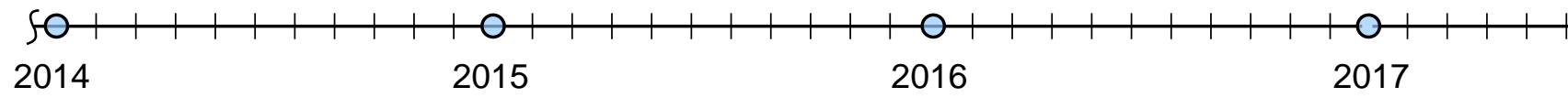
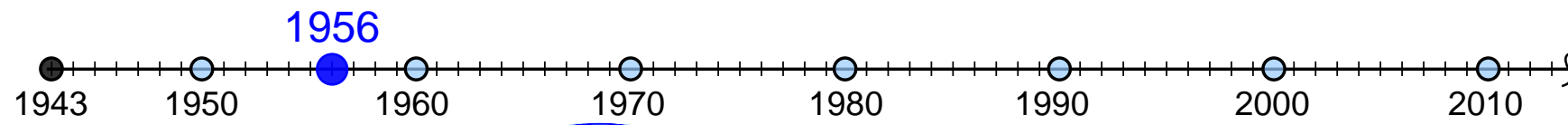

Legend

New Roofing

- Original roofing system was roll-roofing over panelized wood sheathing
- Roof was upgraded to corrugated aluminum panels over roofing felt in 1956
- Approximately **466,000** ft² of roofing per hangar

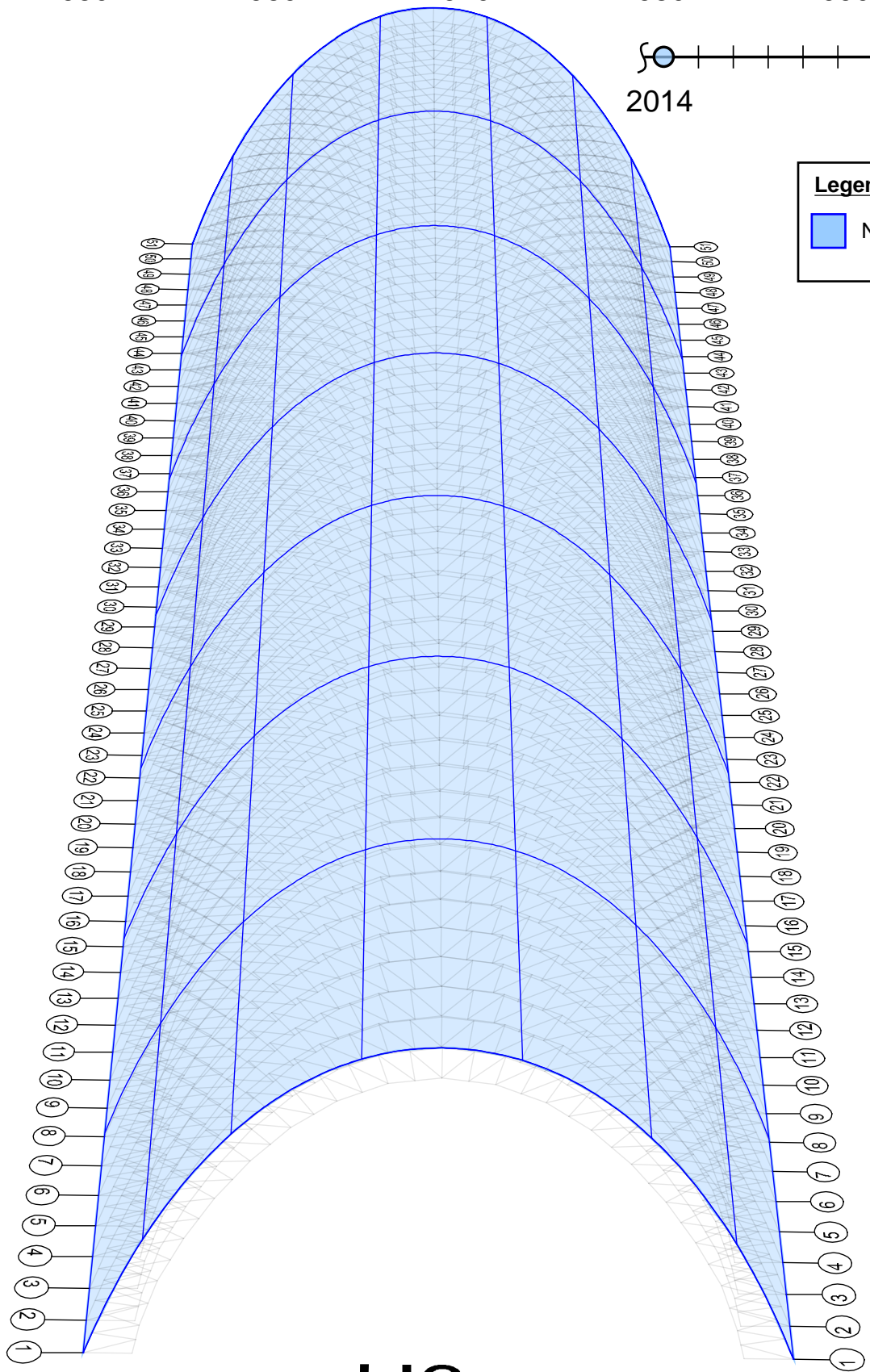

H3



Original roofing system
-Seabees Historic Photos



Asphalt shingles documented in 1954
-Seabees Historic Photos



Current aluminum roofing

MAINTENANCE REPAIRS

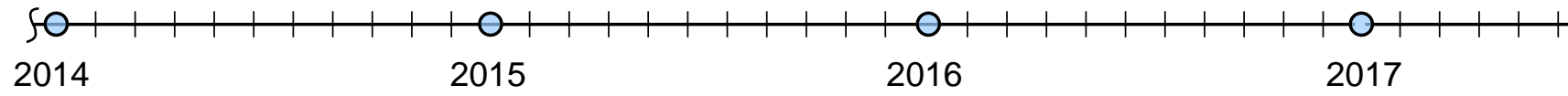
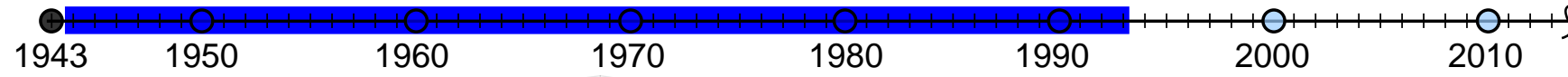

DRAFT - 7/6/2017
SED

Legend

■ Documented existing minor repairs

- Standard repairs for Navy maintenance included steel clamps and stitch bolts to fix minor splits "Maintenance Procedure for Timber Trussed Structures" Department of Navy Bureau of Yards and Docks, 1944
- Repairs occurred periodically throughout the service life of the hangars
- Navy records indicate that Timber Structures performed an inspection of the hangars in 1954
- The extent of these repairs is not fully documented
- Minor repairs have been documented at **541** members in H3 (many still undocumented)

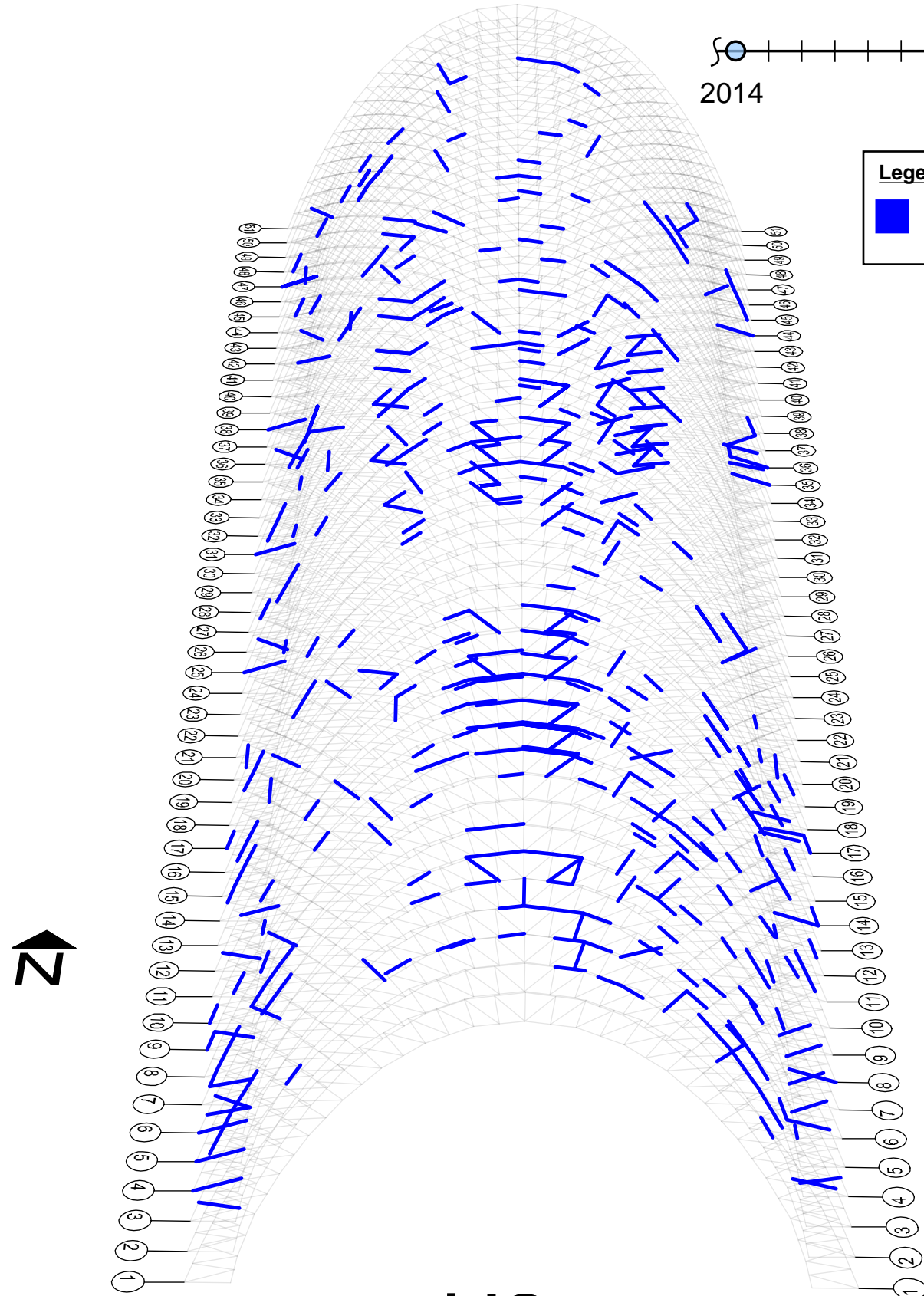

H3

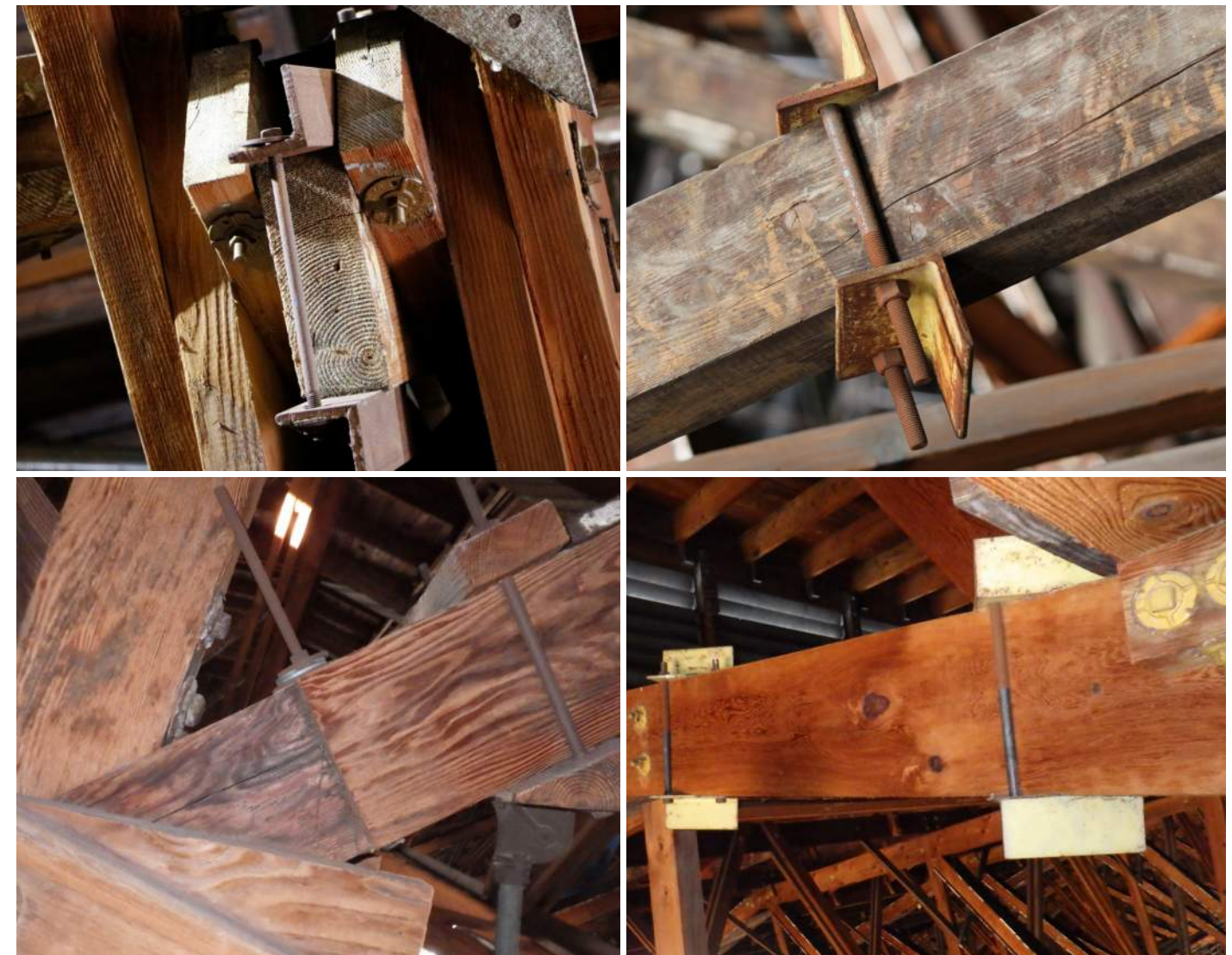

Minor repairs made during Hangar 3 service life

1981 REPAIRS

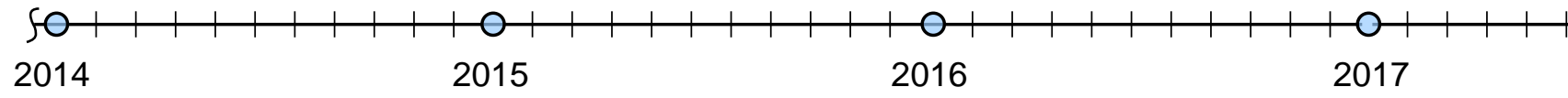
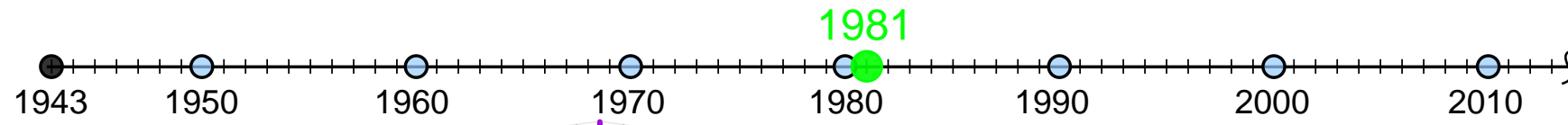

Legend

- 1981 Glulam Repairs
- Node 18 Struts
- Rod Cross-Braces

- Major glulam repairs were made in 1981 to correct buckling observed in truss chords
- Glulam strongback members were installed to re-align chords, but load path remained in the original members
- Major repairs made to **49** members
- Struts added at each arch at node 18 to brace top of truss, with rod cross-bracing added at the north and south ends of the hangar
- Minor repairs were also made with clamps and stitch bolts. Many 1x6 purlin ties were replaced with steel rod ties

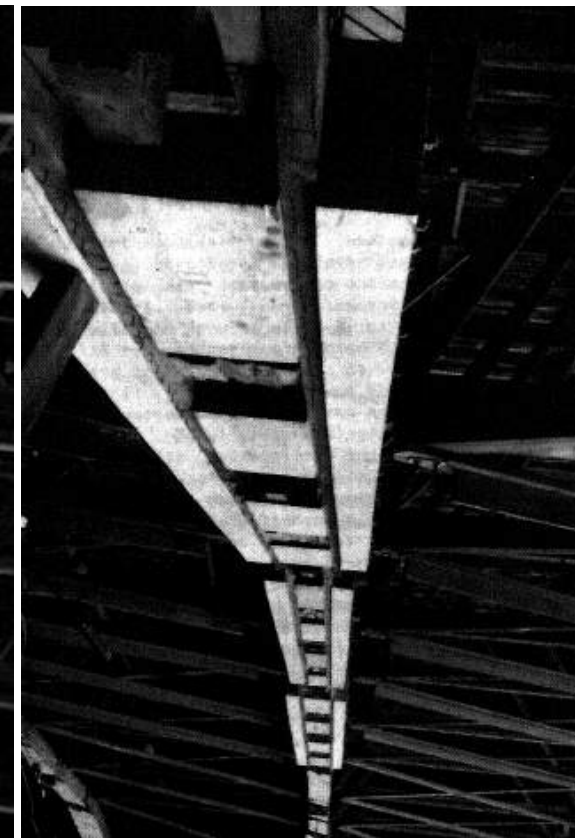
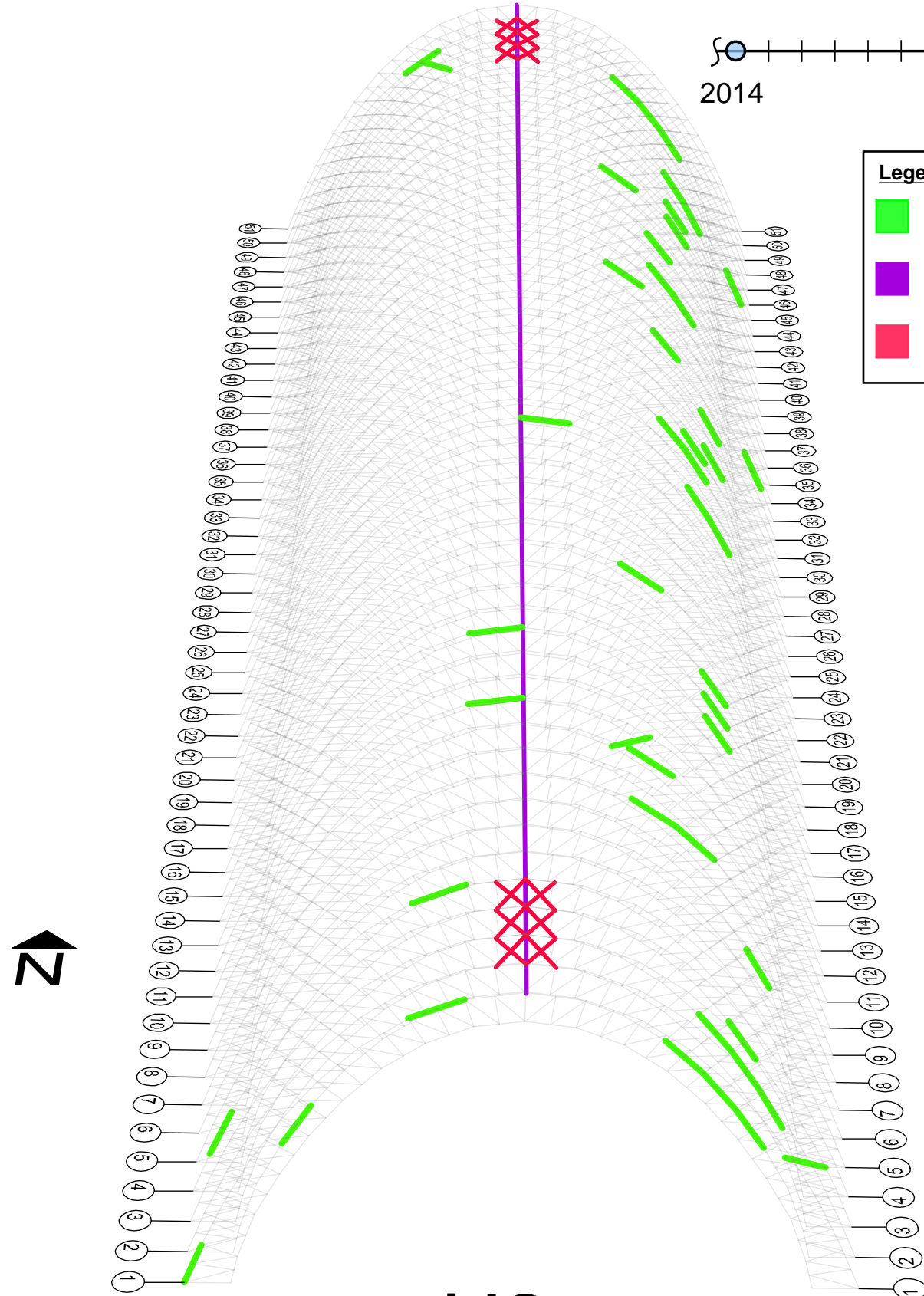

Buckled chords (left) and glulam strongback repairs (right)
- "Restoration of Navy LTA (Lighter than air) Hangars", Donal Neal, 1986



Node 18 struts

1993 GLULAM REPAIRS

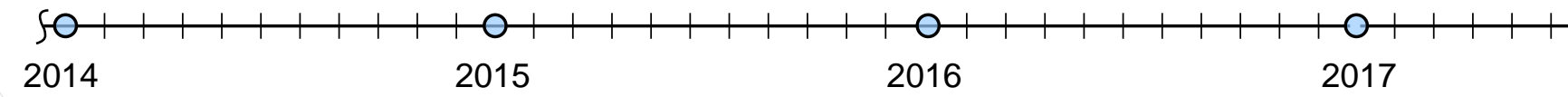
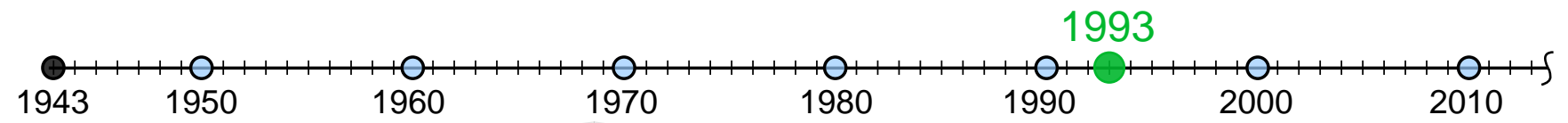

DRAFT - 7/6/2017
SED

Legend

- 1981 Glulam Repairs
- 1993 Glulam Repairs

- Continued deterioration of Hangar 3 necessitated further glulam repairs in 1993
- Repairs consisted of glulam strongbacks for buckling, and multi-chord glulam sistered members
- Many of these repairs were made in the critical zone where the most severe deflections and damage were later found
- Major repairs made to **75** members
- Sistering repairs also made to roof support purlins and minor clamp repairs were again performed on arch trusses

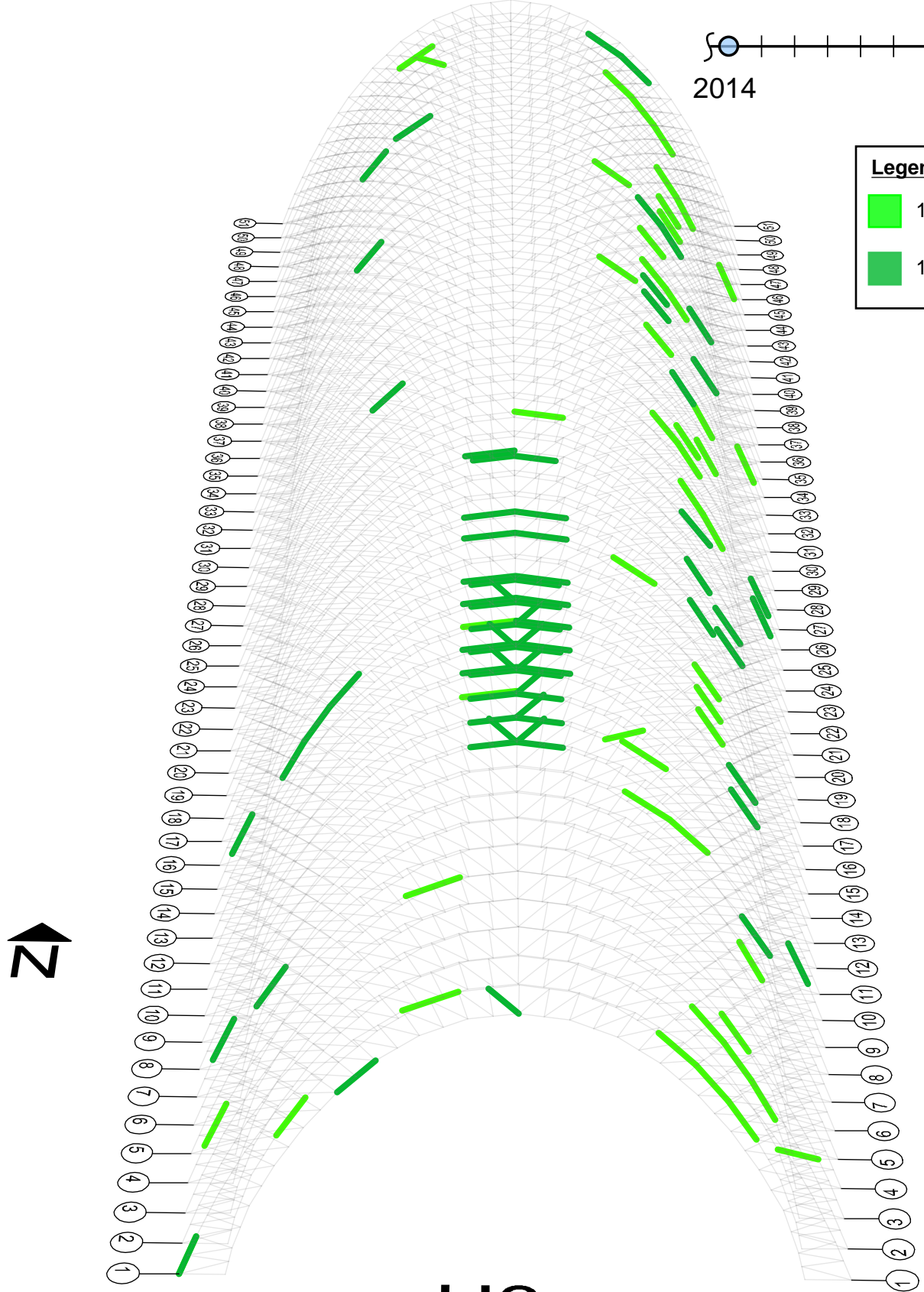

1993 glulam sister repairs to chord members in critical zone

H3

DUE DILIGENCE INVESTIGATIONS

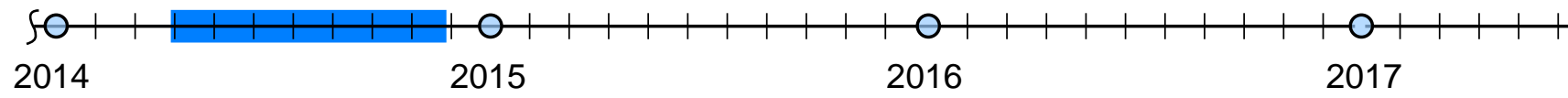
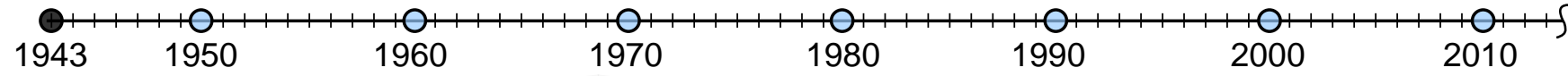

DRAFT - 7/6/2017
SED

Legend
 Members surveyed in Due Diligence Investigations

- Data collected in the Due Diligence Investigations phase of the project included visual observations of many (but not all) of the truss members
- Observations were made regarding wood grading, existing condition, and previous repairs
- Data was logged for **5663** members in H3 through TPAS® (Tablet PC Annotation System) provided by Vertical Access
- H3 contains over **20,000** total members, including **5559** main arch members
- Results summarized in Page & Turnbull Due Diligence Investigations Findings Report (DDIF)

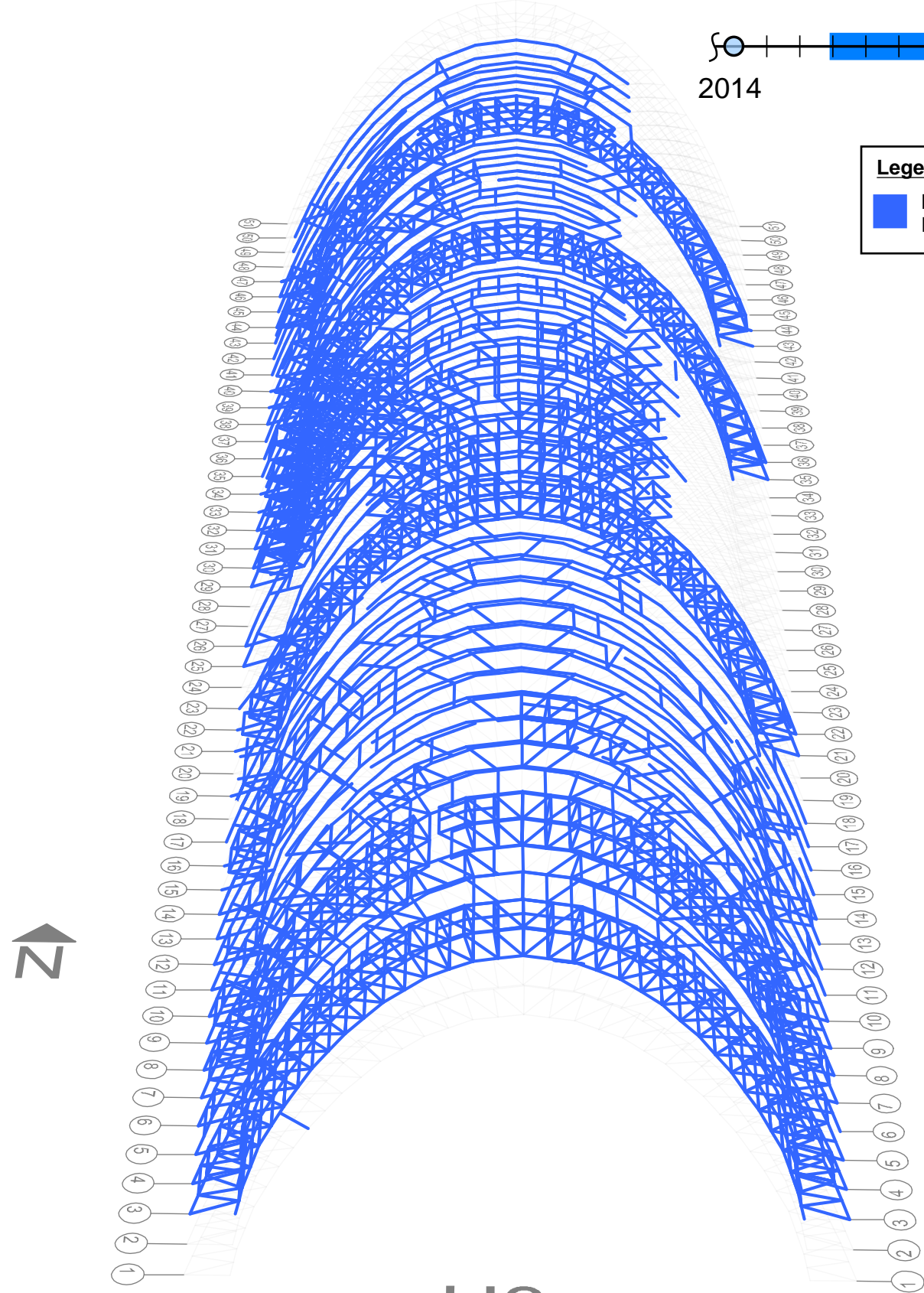

H3



Boom lift used for visual observations



Visual observation of a lower chord member

DDIF REPAIR SCOPE

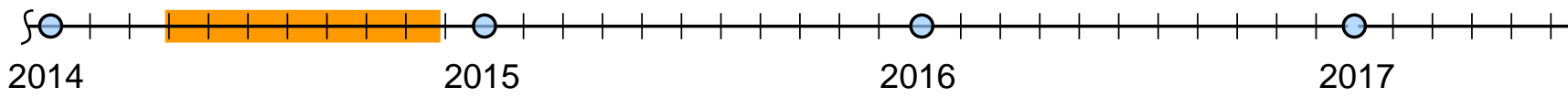
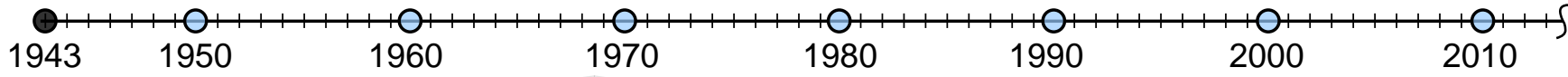

DRAFT - 7/6/2017
SED

Legend

- █ 1981 Glulam Repairs
- █ 1993 Glulam Repairs
- █ DDIF Repair Scope

- TPAS® data was reviewed and damaged members were identified for repair
- **68** members were found to be damaged and in need of major repairs

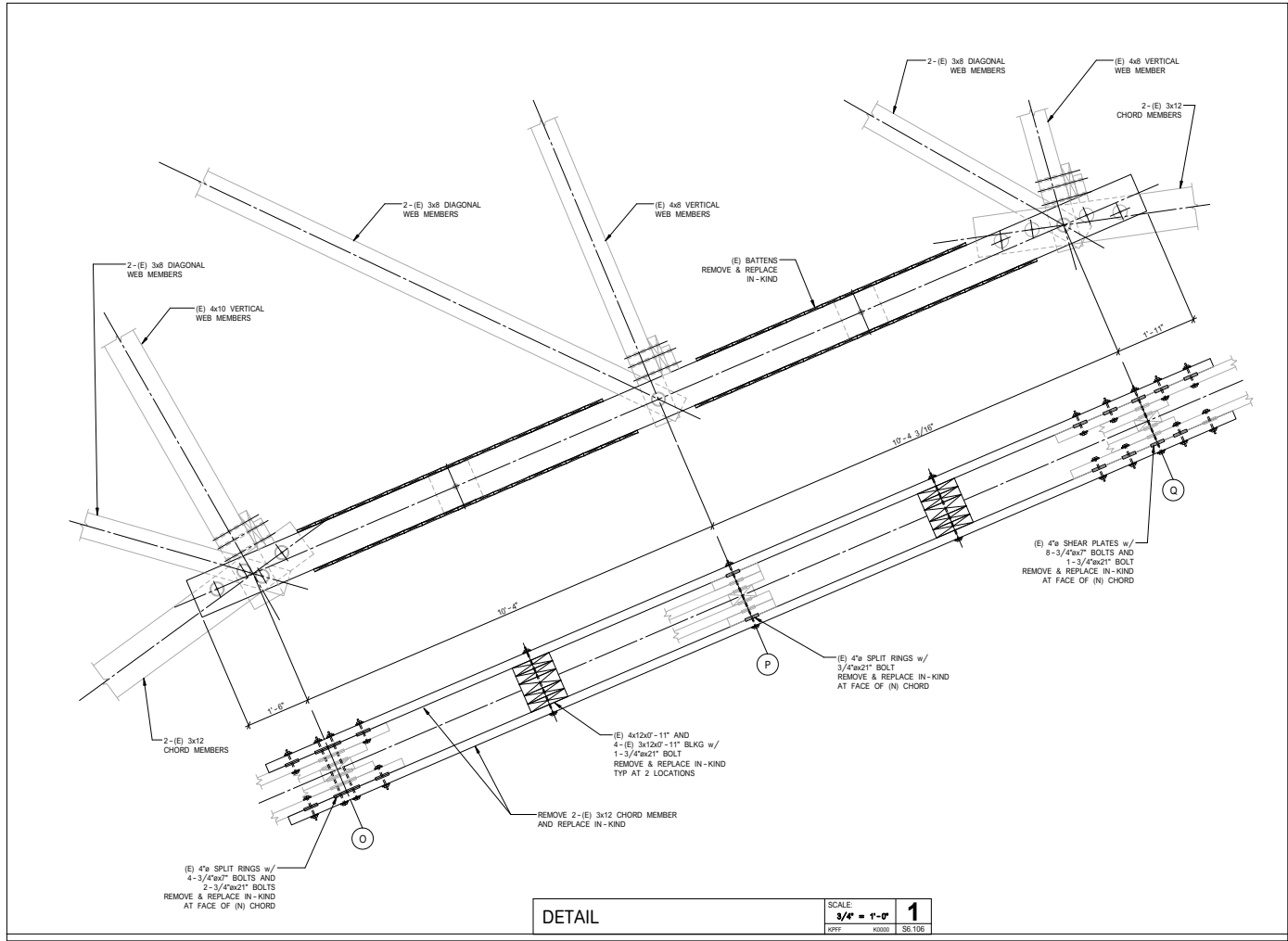
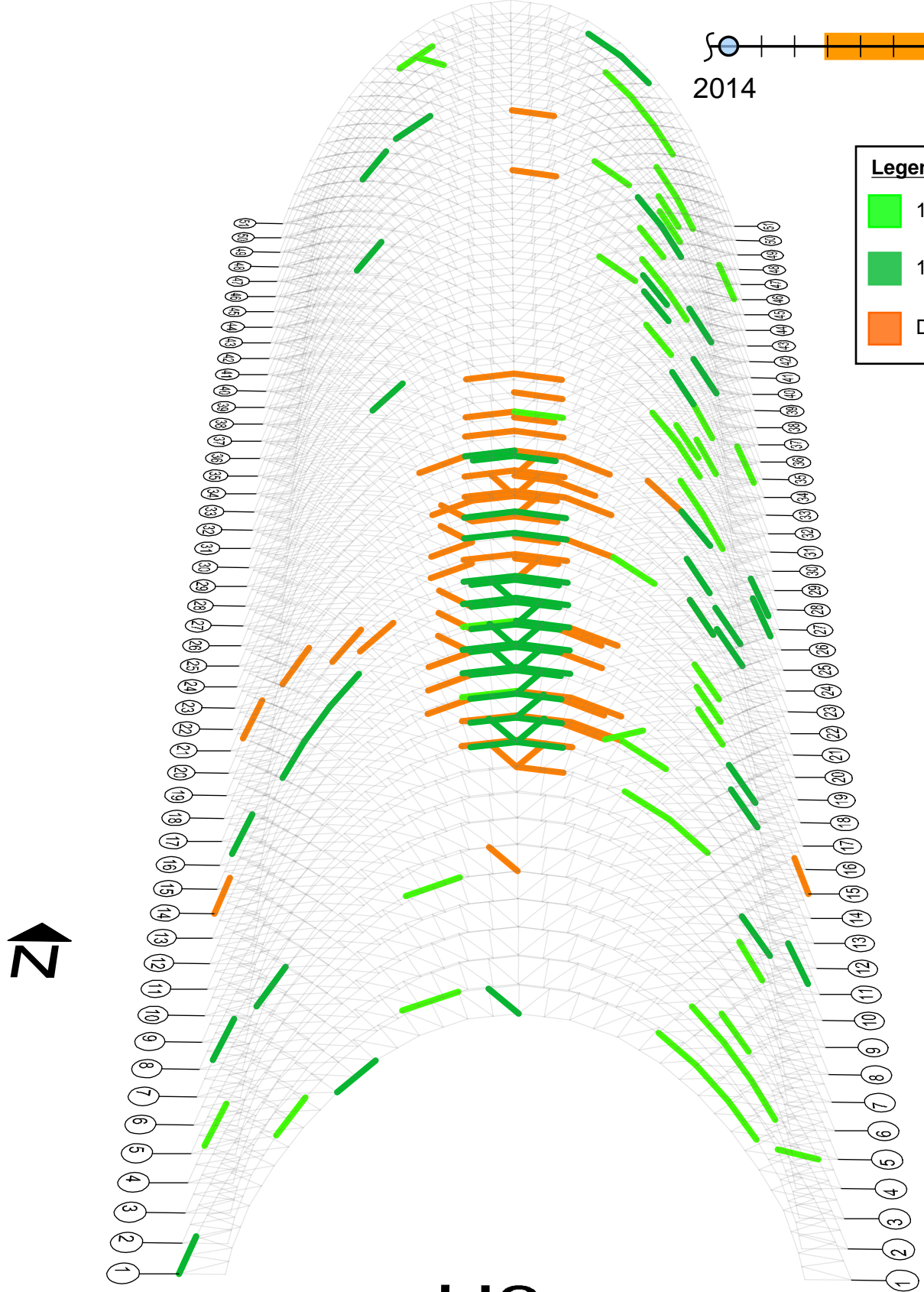

Example detail for removal and replacement of damaged chords found in TPAS®

H3

EMERGENCY REPAIRS

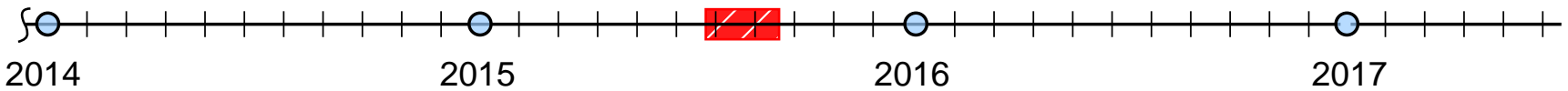
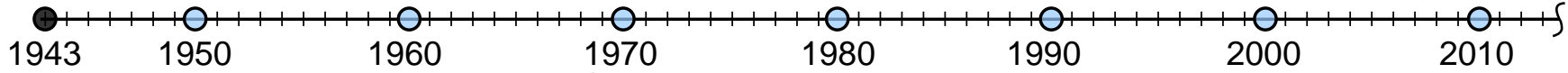

DRAFT - 7/6/2017
SED

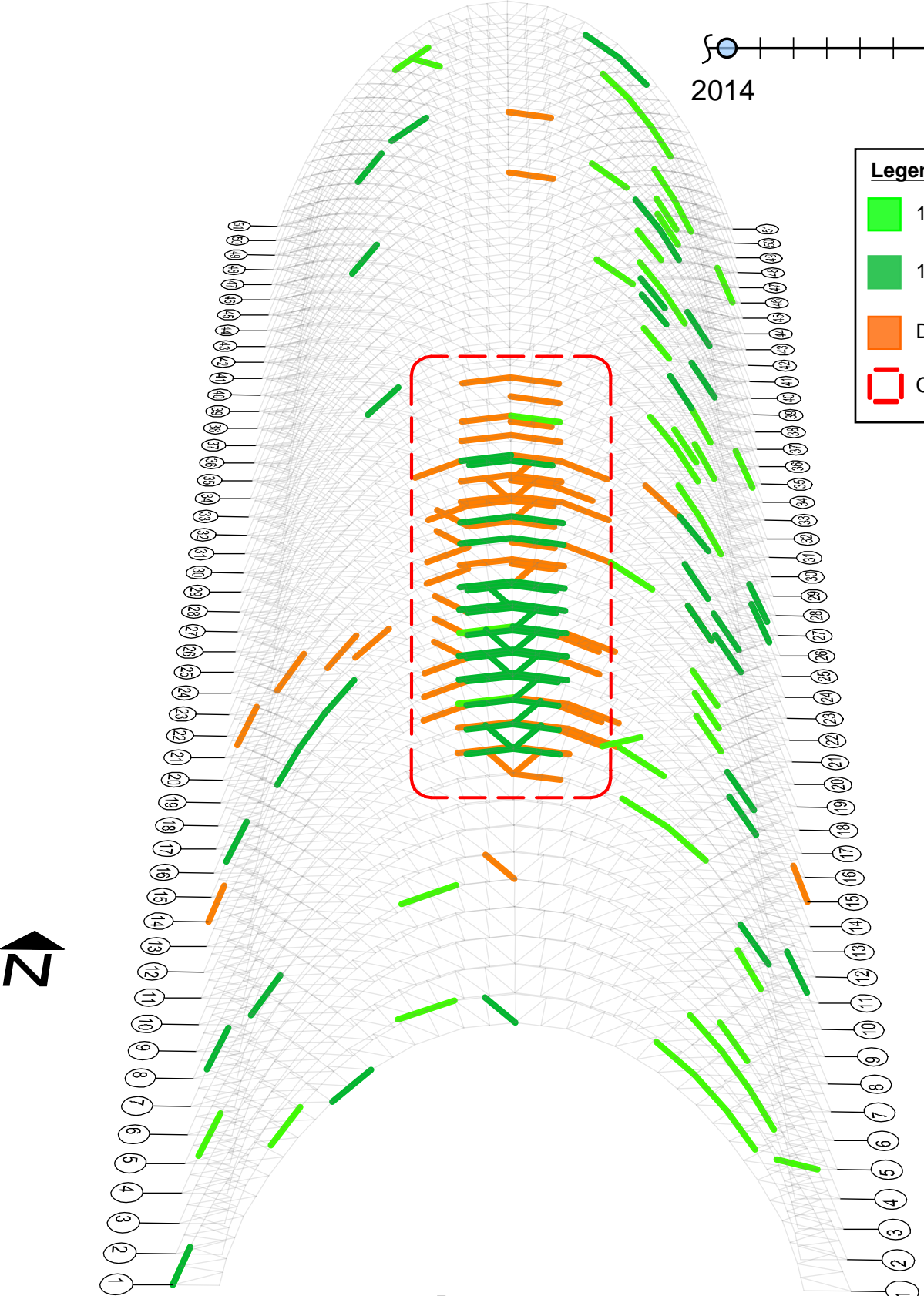

Legend

- █ 1981 Glulam Repairs
- █ 1993 Glulam Repairs
- █ DDIF Repair Scope
- Critical damage zone

- During a site visit on June 24, 2015 KPFF observed damage progression in arch trusses
- On July 2, 2015 KPFF issued an Emergency Truss Repairs permit drawing set
- KPFF, Power Engineering Construction, Turner, and Page & Turnbull coordinated work to implement shoring and emergency truss repairs
- Permit for emergency repairs was received from NASA on August 19, 2015.

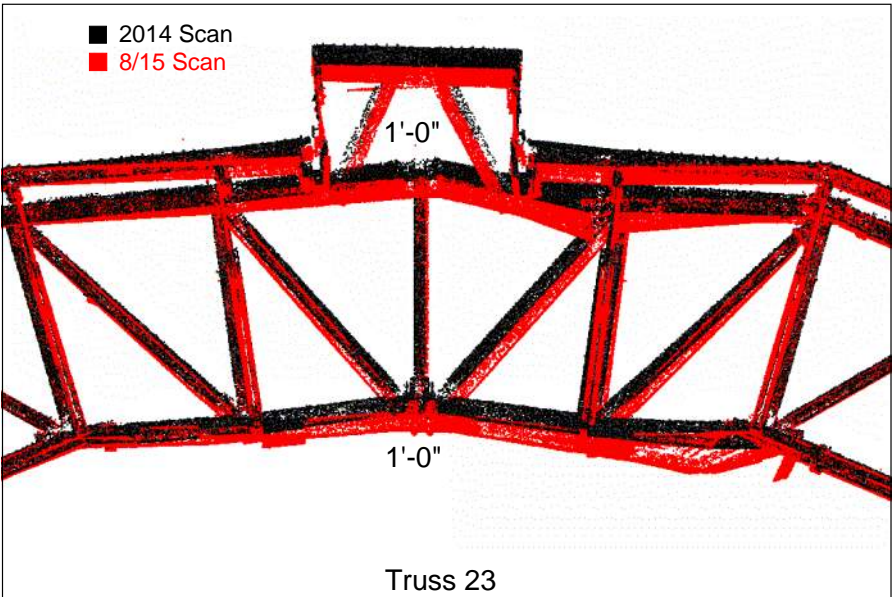

Point cloud visualization of damage progression

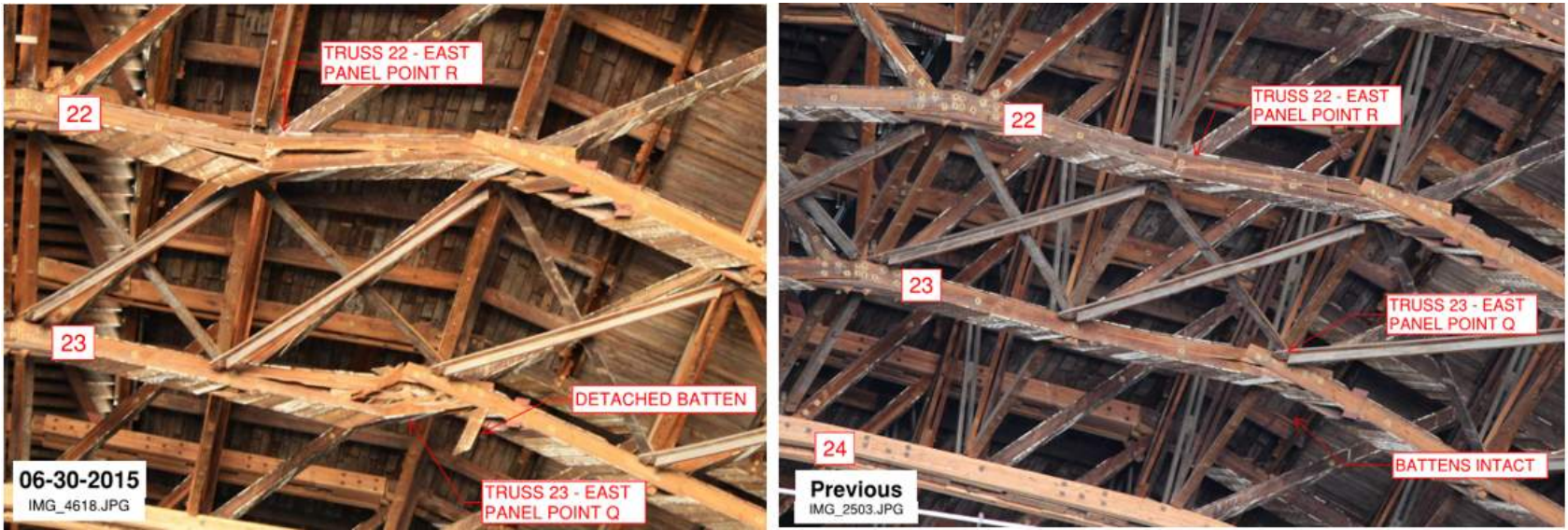

Photos of damage progression

TEMPORARY SHORING

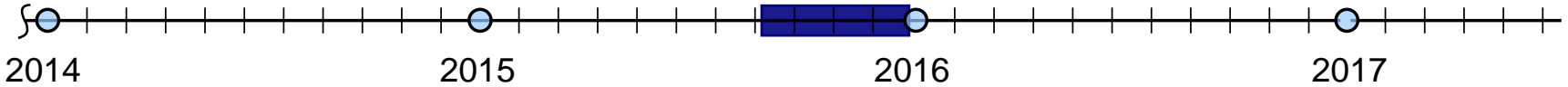
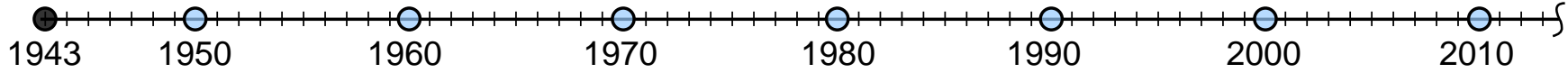

DRAFT - 7/6/2017
SED

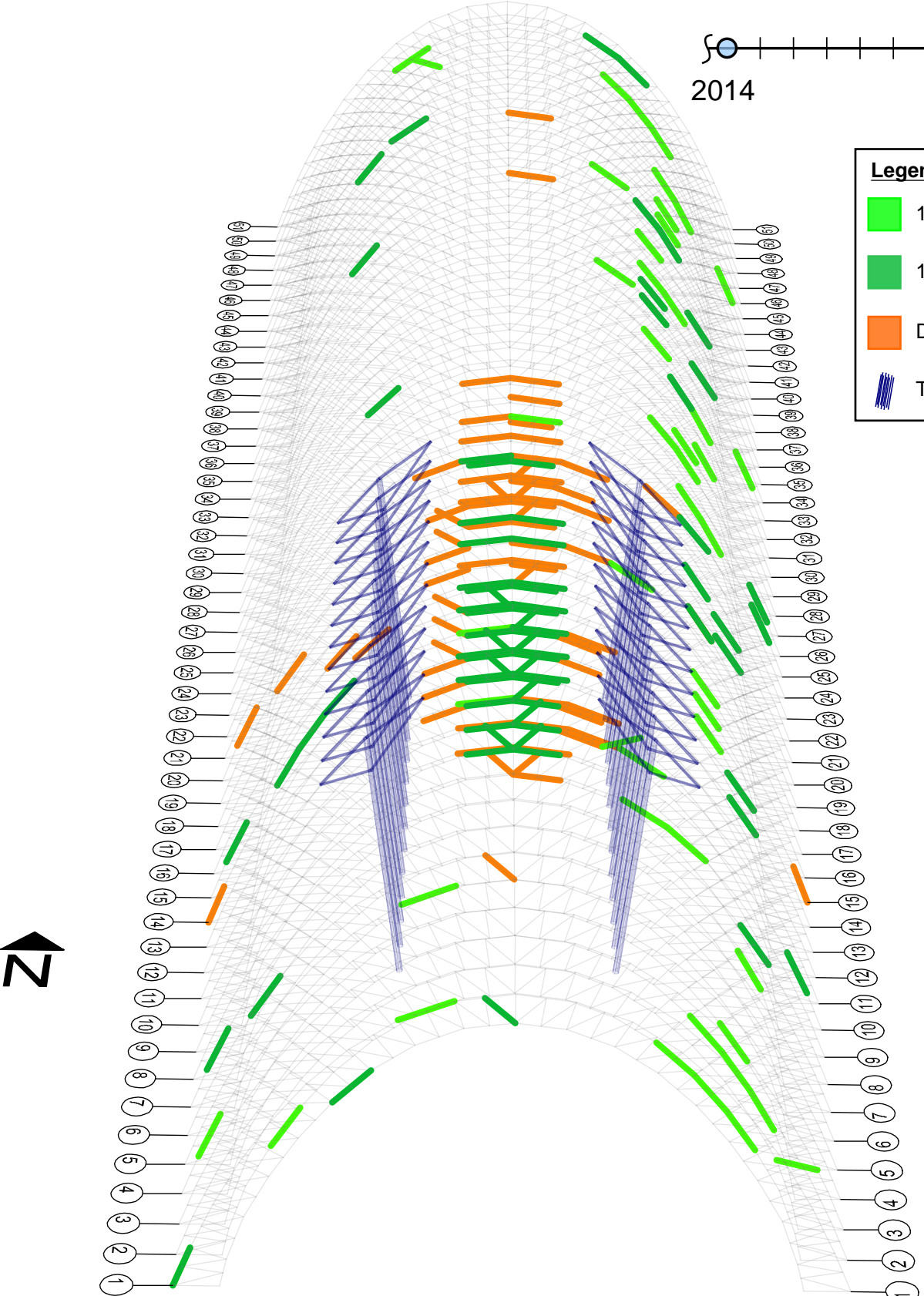

Legend

- █ 1981 Glulam Repairs
- █ 1993 Glulam Repairs
- █ DDIF Repair Scope
- █ Temporary Shoring

- Evidence of severe damage and progressive collapse of Hangar 3 necessitated a shoring and emergency repair program
- As part of the contractor's means and methods of performing repairs, 36"Ø steel pipe shores were placed between trusses 9-26
- Pipe shores were designed to provide secondary stability in the event of progressive roof collapse during repair procedures
- Steel exoskeletons with jacks would then be placed at top to jack the roof and rebuild the critical zone



Hoisting of temporary shore segment



Temporary shores after installation

OBSERVATIONS BELOW EXOSKELETON

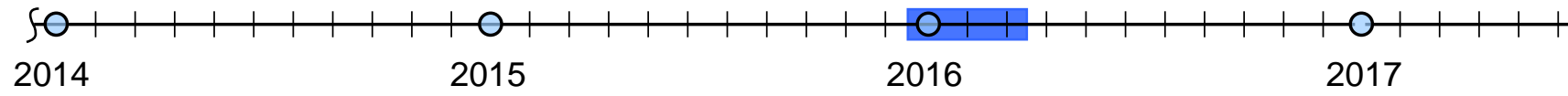
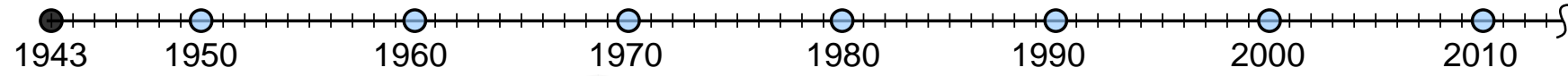

DRAFT - 7/6/2017
SED

Legend

- Members surveyed below exoskeletons
- Temporary shoring

- Before the exoskeletons could be placed, the condition of the trusses below had to be verified to ensure they could take the additional weight
- Any damage of main arch members needed to be repaired prior to exoskeleton installation
- KPFF conducted a survey of main arch members between Trusses 9-26 below panel point O and 14
- **1548** main arch chords and webs were surveyed for damage

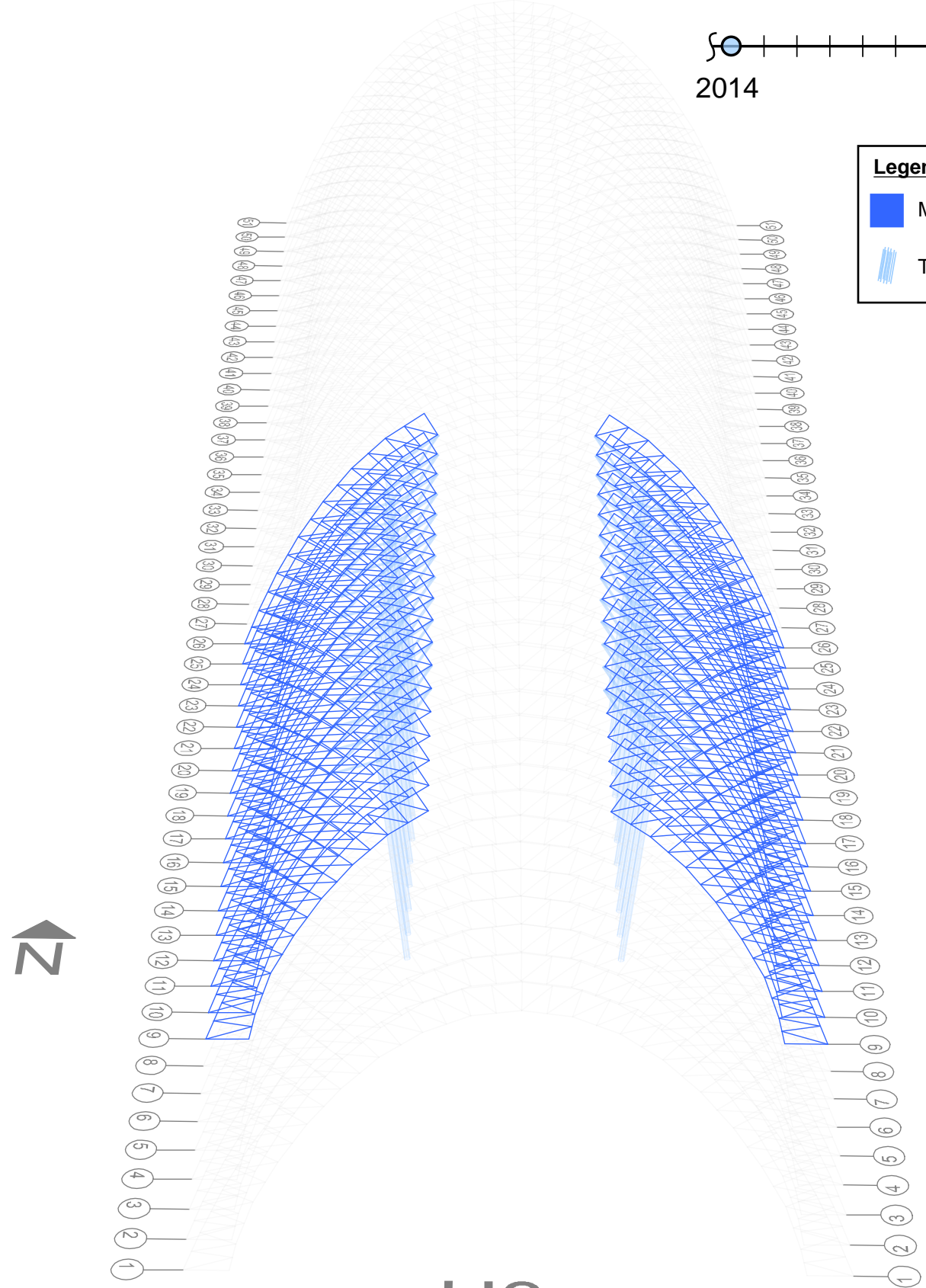

Boom lift used for visual observations



KPFF condition assessment crew

PRE-JACKING REPAIR SCOPE

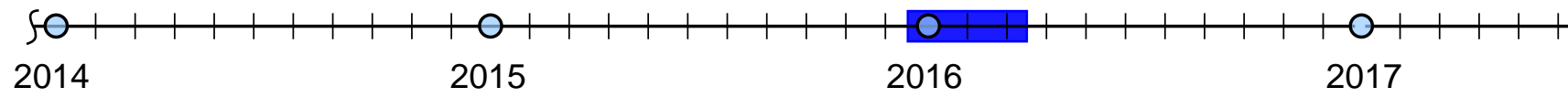
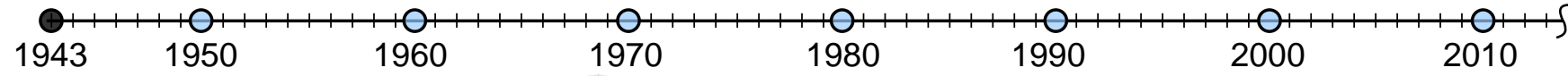

DRAFT - 7/6/2017
SED

Legend

- █ 1981 Glulam Repairs
- █ 1993 Glulam Repairs
- █ DDIF Repair Scope
- █ Pre-jacking sister repair
- Pre-jacking connection strengthening bracket

- The KPFF survey discovered chord damage which was either not observed or not present during the due diligence investigations
- The survey uncovered extensive deficiencies within the web member connections, including many plug pullout failures
- **10** additional arch members received glulam sistering repairs
- **39** chord connections received connection strengthening brackets

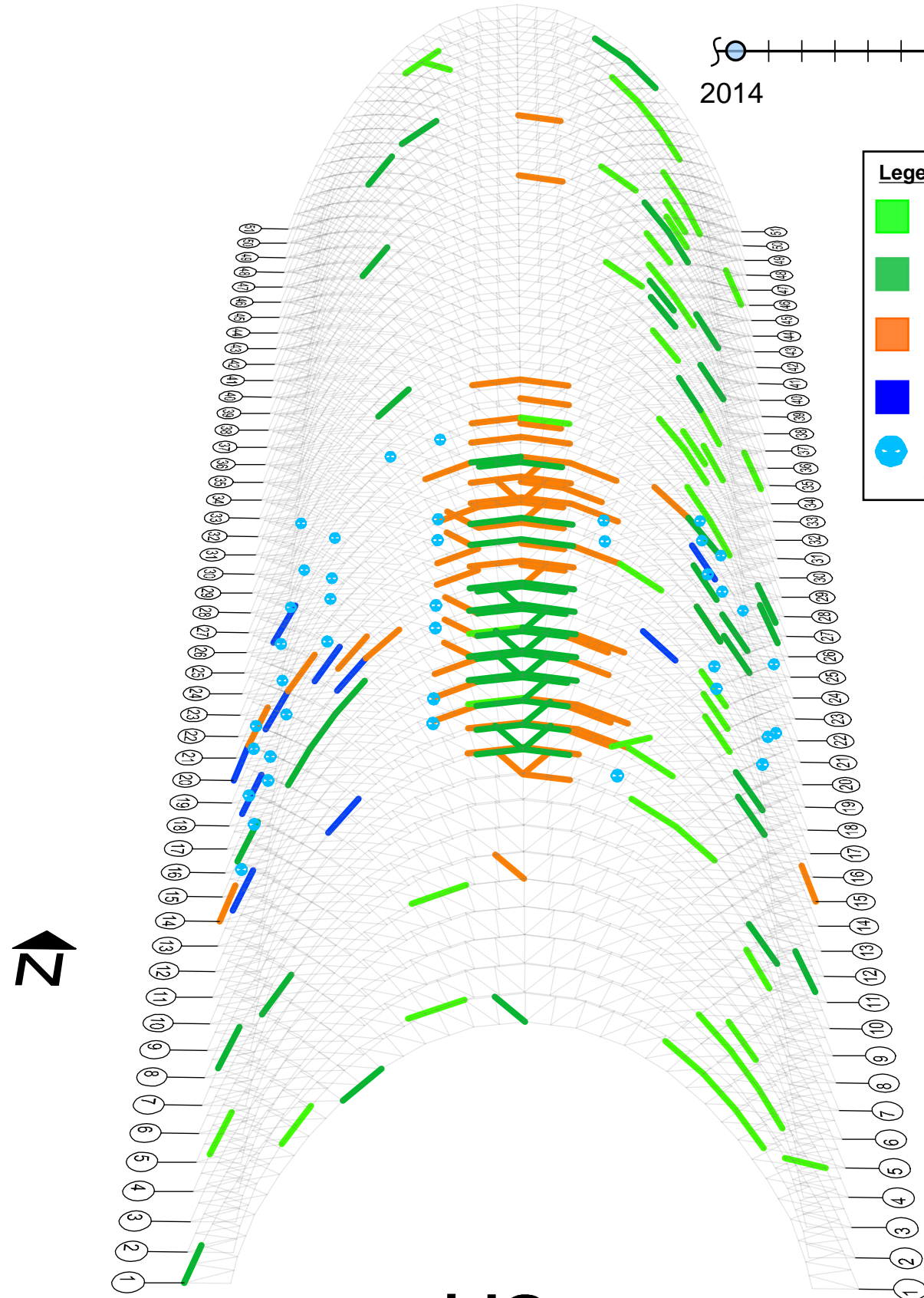

Chord sister repair installed prior to exoskeletons



Typical connection strengthening bracket

ACCESS TOWER OBSERVATIONS

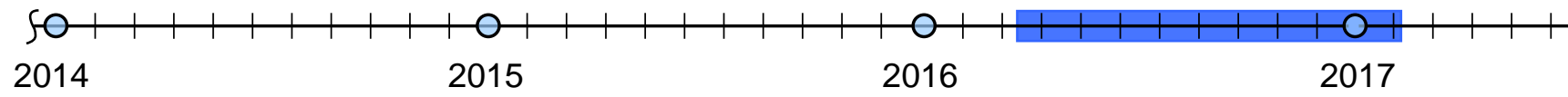
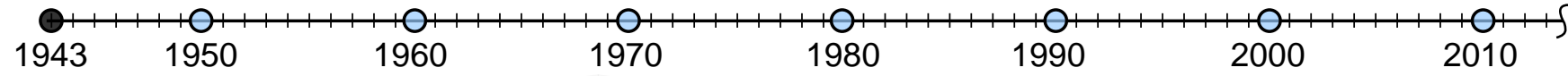

DRAFT - 7/6/2017
SED

Legend

- Members surveyed from tower
- Movable access tower

- The movable access tower provided clearance for KPFF to make additional observations in the zones above the temporary shores
- Chord and web members were observed after each tower move before the exoskeletons were installed
- Additional damage observed in this zone was planned to be repaired after roof jacking

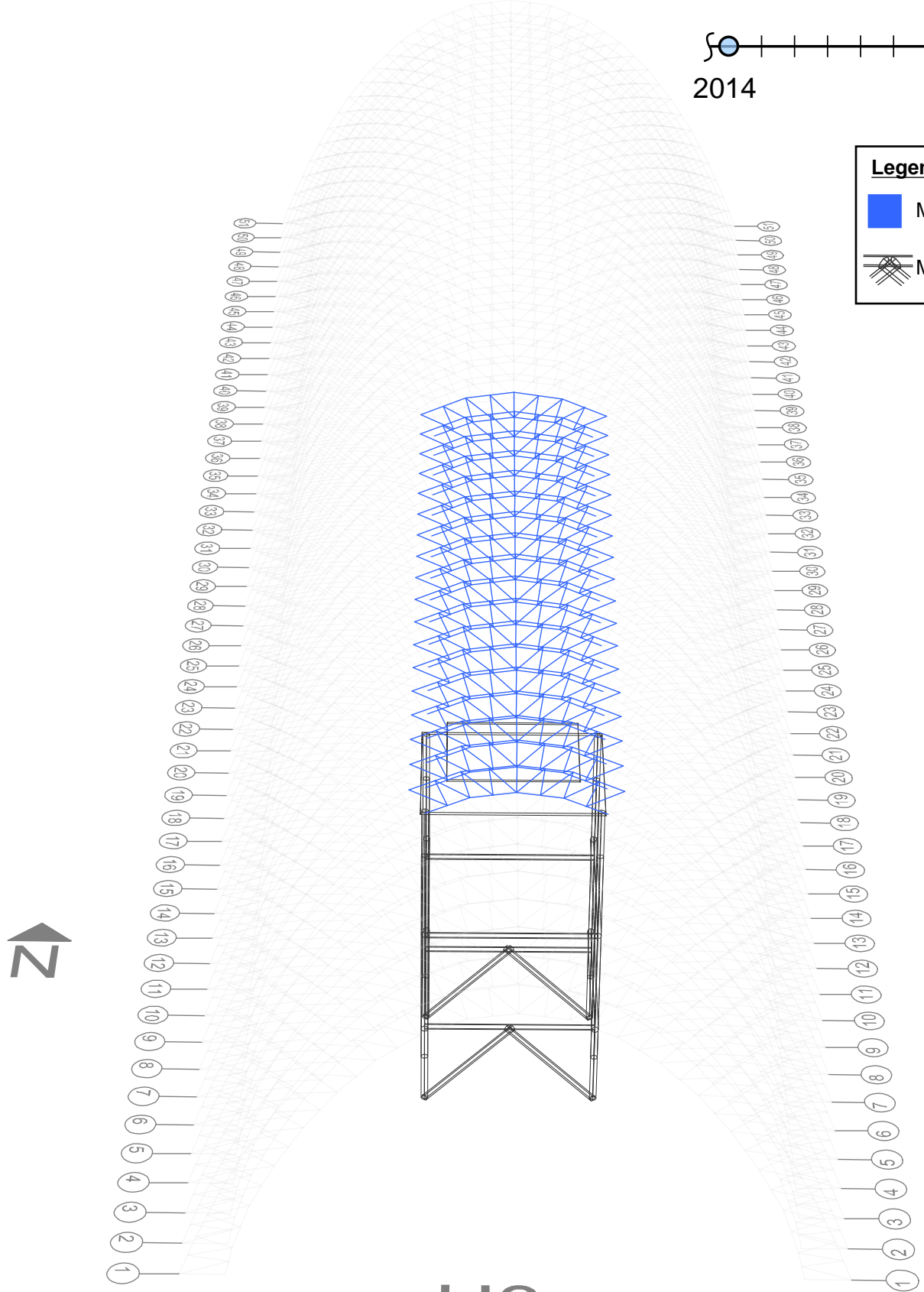

H3



Movable access tower

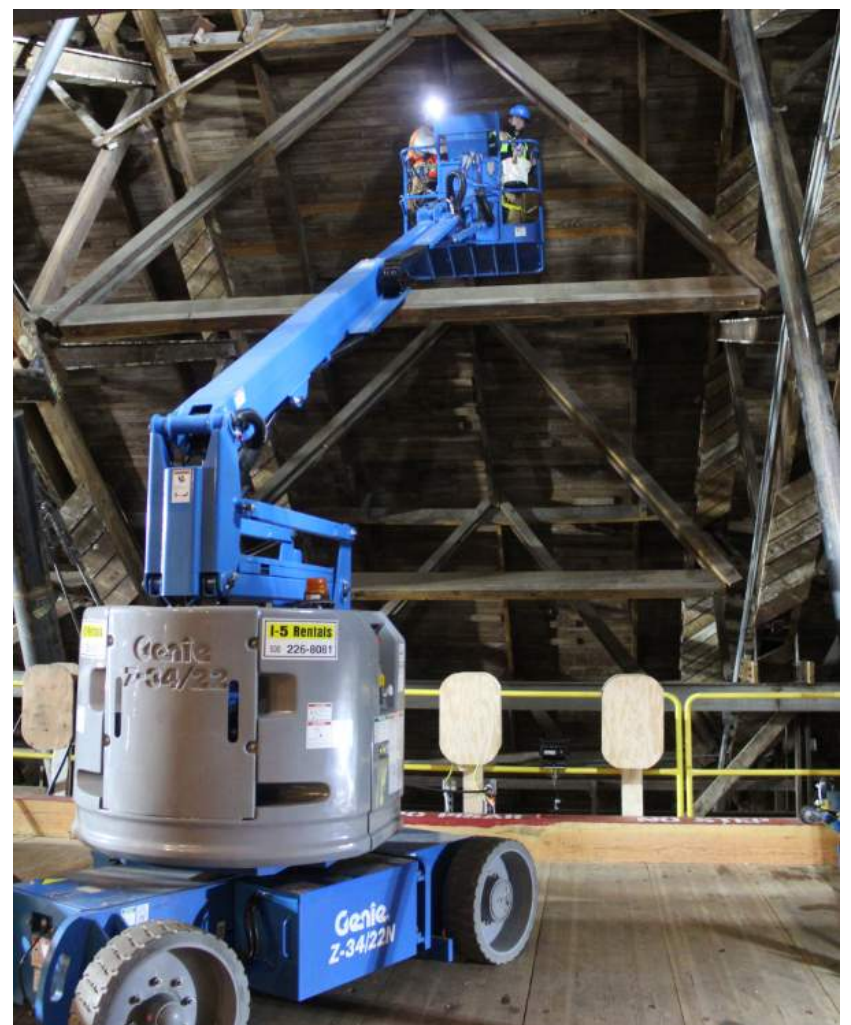

Truss observations from a boom lift on top of access tower

POST-JACKING REPAIR SCOPE

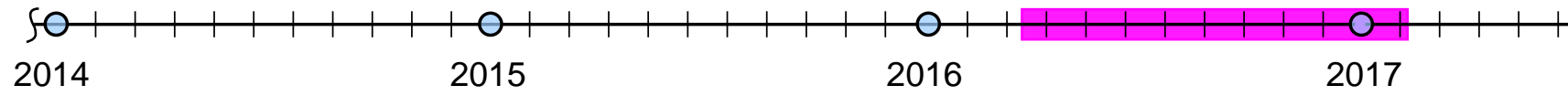
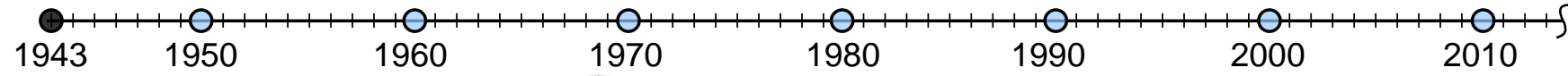

DRAFT - 7/6/2017
SED

Legend

- █ 1981 Glulam Repairs
- █ 1993 Glulam Repairs
- █ DDIF Repair Scope
- █ Pre-jacking repair scope
- █ Post-jacking repair scope

- **50** additional members were identified as severely damaged and scheduled to be removed and replaced after roof jacking
- Before jacking and repairs were made, decision was made to defer further construction activities

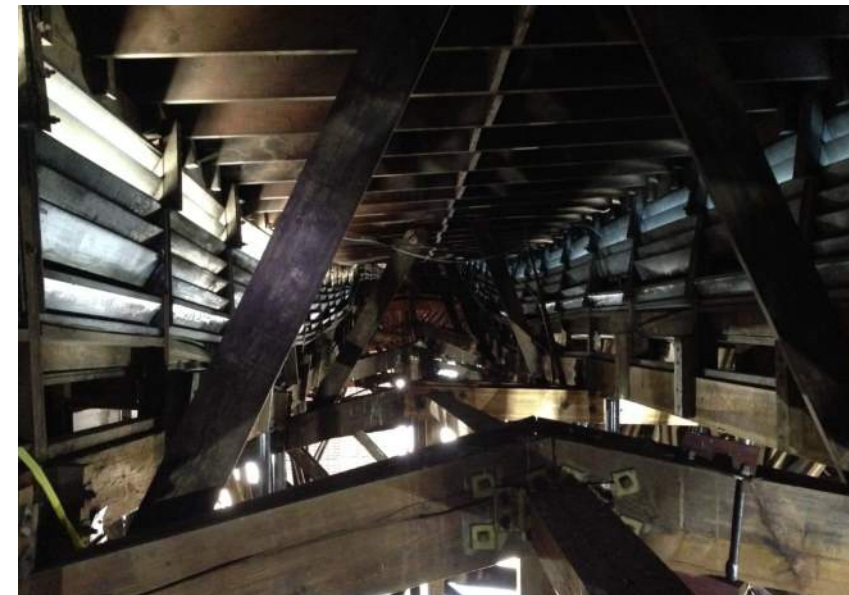

Roof monitor deflection in critical zone

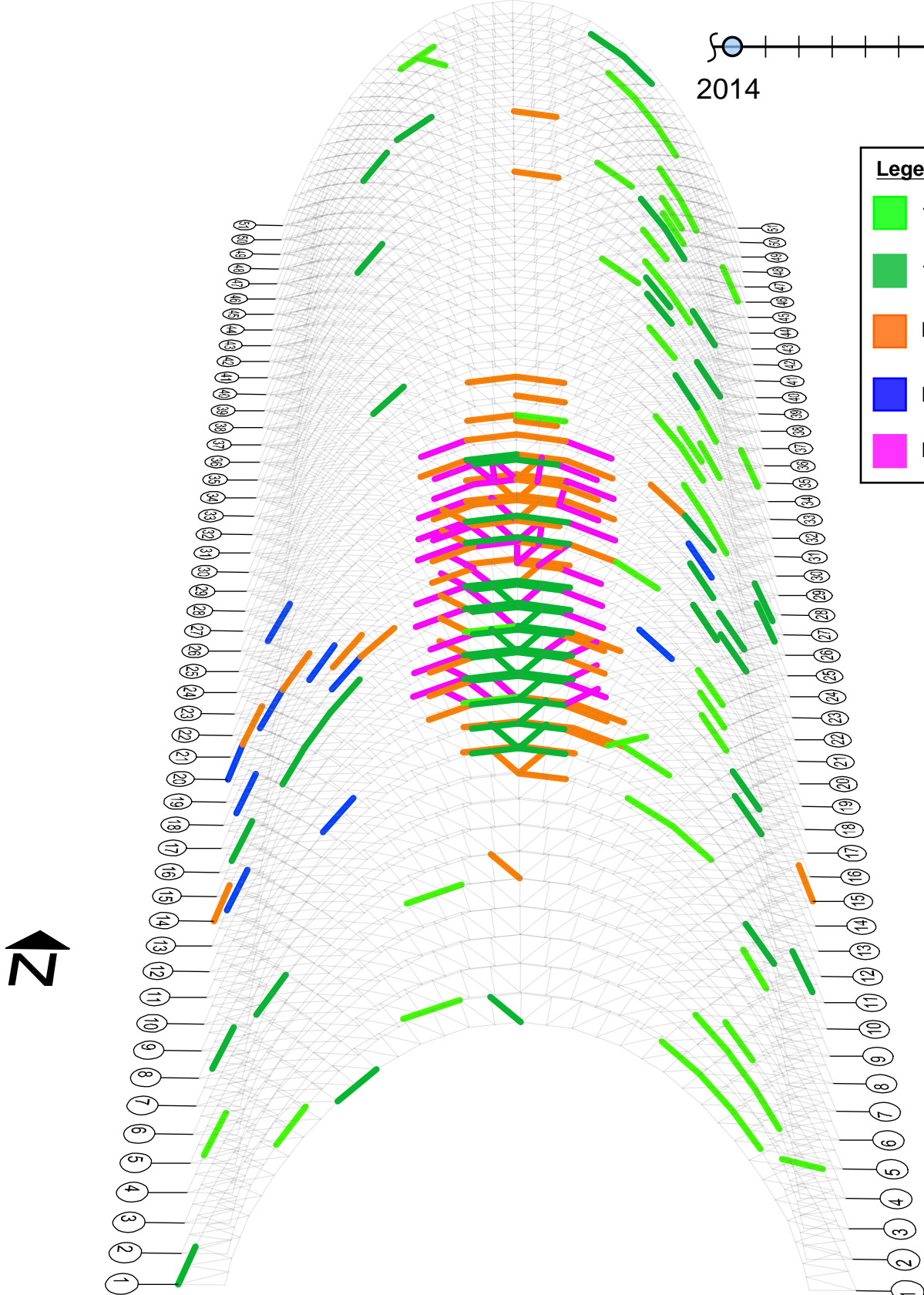

H3

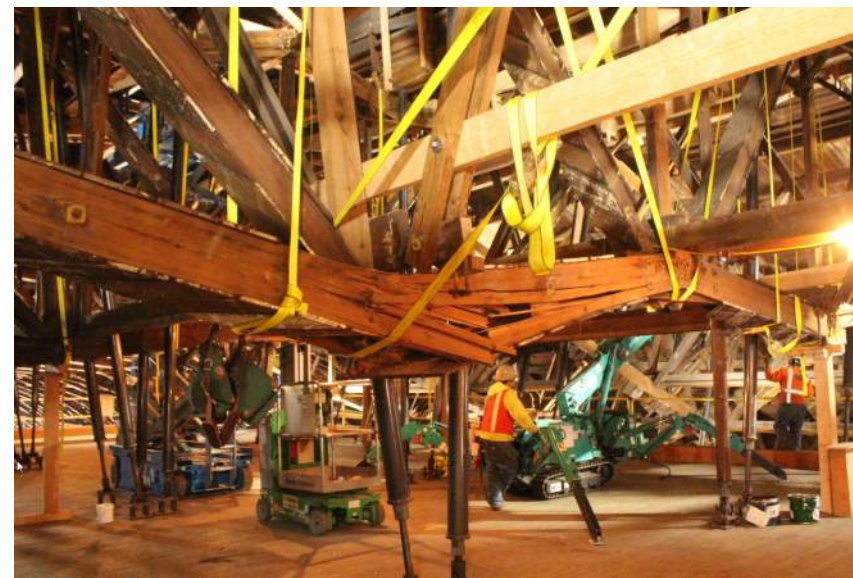

Temporary strapping on chord marked for removal and replacement



Damaged chord member viewed from access tower

EXOSKELETONS

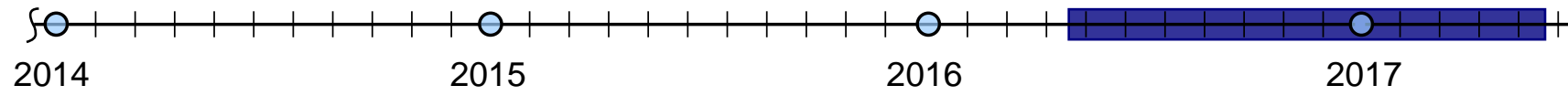
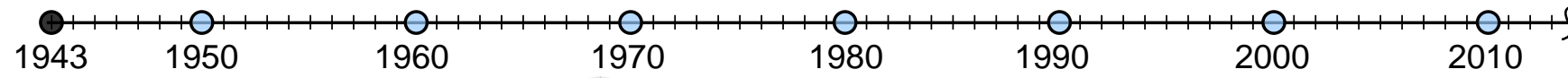

DRAFT - 7/6/2017
SED

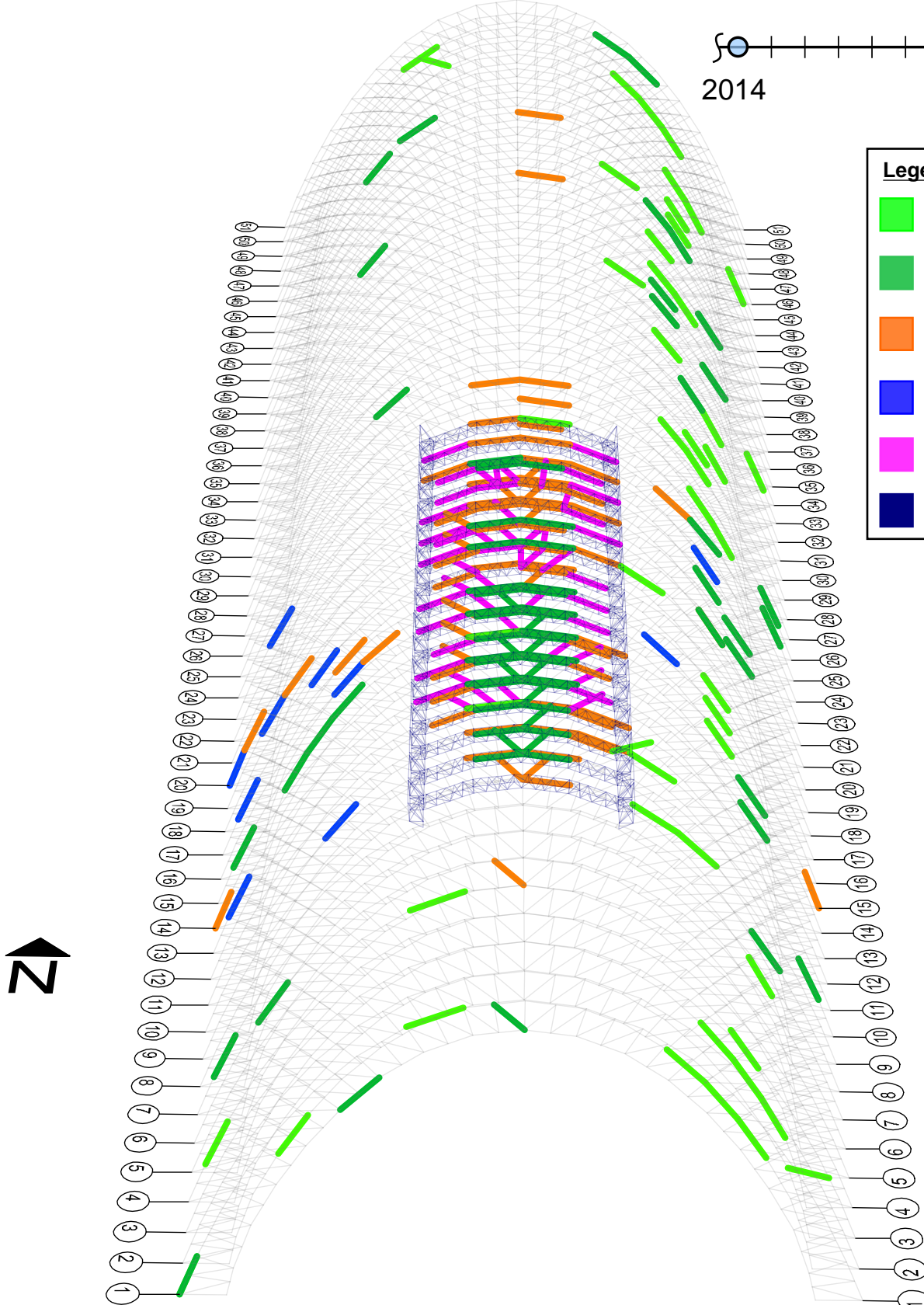

Legend

- █ 1981 Glulam Repairs
- █ 1993 Glulam Repairs
- █ DDIF Repair Scope
- █ Pre-jacking repair scope
- █ Post-jacking repair scope
- █ Exoskeletons

- Steel exoskeletons were installed at Trusses 9-26 after observations were made.



Hoisting exoskeleton segment into place



Installed exoskeletons

DAMAGE PROGRESSION

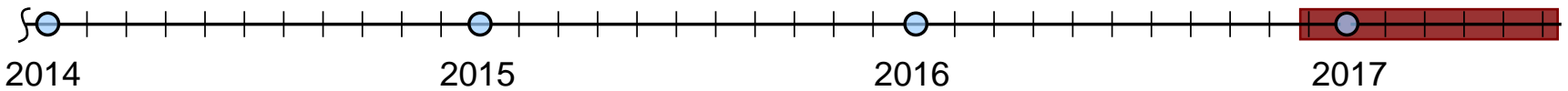
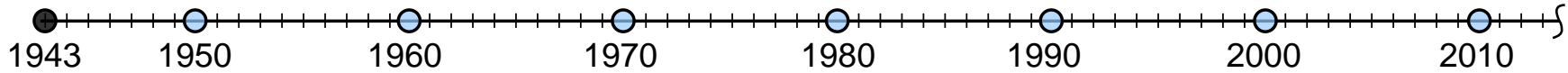

DRAFT - 7/6/2017
SED

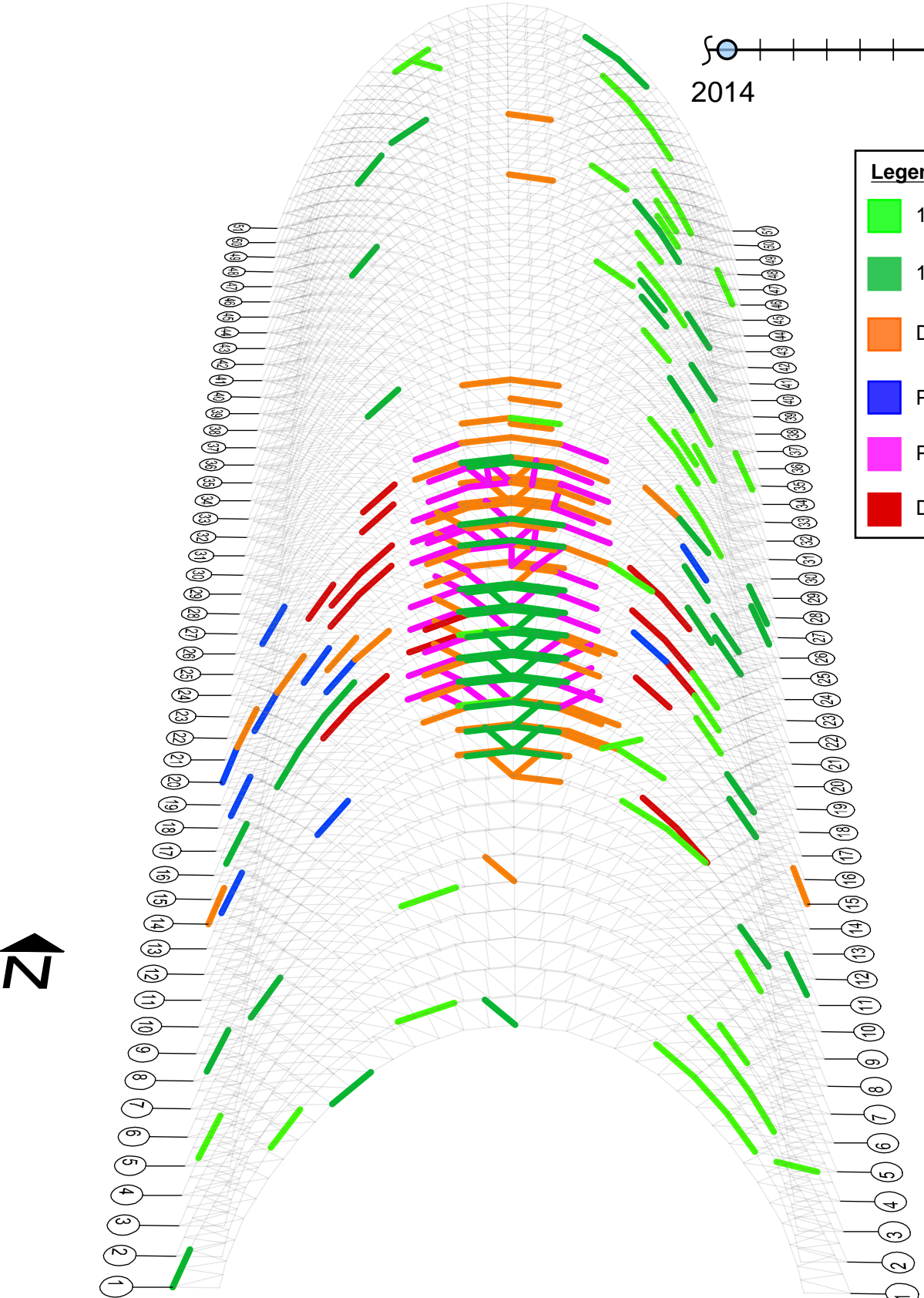

Legend

- █ 1981 Glulam Repairs
- █ 1993 Glulam Repairs
- █ DDIF Repair Scope
- █ Pre-jacking repair scope
- █ Post-jacking repair scope
- █ Damage progression

- Months after installation of exoskeletons, major splits were observed in chord members which had previously been observed and cleared.
- Major damage was observed on **19** chords, most between panel points I to M.
- Sistering repairs installed on most severe cases
- Due to the concentration of new damage at the lower chord members at panel points I to M, preemptive measures were taken to help reduce the progression of damage.
- Preemptive measures included fully-threaded screws at connections, and steel clamps.



Chord damage at node K after exoskeleton install



Preemptive screw and clamp strengthening on undamaged chord at node K

A.4 - Structural Site Observations



August 21, 2019

Sallie Lim
Director
Legal Department / Google Inc.
1600 Amphitheater Pkwy
Mountain View, CA 94043

VIA Email: sallie@google.com

Gary S. McKitterick, Esq.
Partner
Allen Matkins Leck Gamble Mallory & Natsis, LLP
1900 Main Street, 5th Floor
Irvine, CA 92614-7321

VIA Email: gmckitterick@allenmatkins.com

Subject: Moffett Federal Airfield Hangar 3 – Mountain View, California
Structural Site Observation

Dear Ms. Lim and Mr. McKitterick:

As part of the quarterly Hangar 3 structural assessment, I've recently conducted a site visit on behalf of Planetary Ventures to visually observe the general condition of the existing hangar structure and the temporary shoring devices that were left in place when the work was terminated. After walking the entire Hangar 3 structure, I have prepared the following comments, observations and conclusions:

Overall Comments:

1. The original intent of the emergency truss repair program was to return the damaged and broken arched trusses to their original deficient state.
2. The emergency truss repair program was ultimately abandoned due to the numerous severely damaged arched trusses as well as the damage progression to undamaged trusses which continued to occur during the installation of the required repairs.
3. Once abandoned, additional shores were installed, shoring support elements were left in place and the shoring platform was positioned in a manner to provide asset protection. These steps were meant to be a temporary or short term solution to assist with the protection of the damage elements.
4. The structure remains unsafe and is very vulnerable to further damage or partial collapse while left in its current unrepaired state.



Observations:

5. Upon arrival at the site, the hangar was locked up and not accessible as previously recommended.
6. We did not observe any wood material or other debris which had fallen from the existing framing to the hangar deck below.
7. It was not apparent that further damaged had appeared since our last site visit and the monitoring program has been discontinued.

Conclusions:

8. Overall, the hangar structure has existed well past its original design life. Varying levels of damage exist to other parts of the timber framing, beyond that of the work outlined in the Emergency Truss Repair work. Subsequently, the level of repair required to return the hangar to its original deficient state is excessive and cost prohibitive.
9. The shoring and platform shoring, which were left in place as a means of providing short term asset protection were only intended to be short term. Previous discussions had placed the time limit describing "short term" at roughly 2-3 years maximum.
10. Further, in its current unrepaired state, the structure is far more vulnerable to sustaining further damage and even experiencing partial collapse of areas from earthquake and/or high wind loading.
11. Finally, it is my professional opinion, that the structure left in its current unrepaired and unsafe condition is likely uninsurable.

Based on my discussion above, it remains my professional opinion that the hangar is unsafe, should not be occupied and could become a potential site hazard from seismic and/or high wind forces. In addition, the work required to return the hangar to a limited Occupiable use level, is extensive and undefinable and further, the necessary work required would be cost-prohibitive and is therefore not salvageable.

This concludes my structural site visit observation report and status update on the existing hangar 3 structure. Please feel free to contact me if you have further questions or comments.

Very truly yours,

A handwritten signature in blue ink, appearing to read "Blake W. Dilsworth".

Blake W. Dilsworth, S.E.
Principal